



九齊科技股份有限公司
Nyquest Technology Co., Ltd.

DATA SHEET

NY8A051A

6 I/O 8-Bit EPROM-Based MCU

Version 1.1

Nov. 26, 2014

NYQUEST TECHNOLOGY CO. reserves the right to change this document without prior notice. Information provided by NYQUEST is believed to be accurate and reliable. However, NYQUEST makes no warranty for any errors which may appear in this document. Contact NYQUEST to obtain the latest version of device specifications before placing your orders. No responsibility is assumed by NYQUEST for any infringement of patent or other rights of third parties which may result from its use. In addition, NYQUEST products are not authorized for use as critical components in life support devices/systems or aviation devices/systems, where a malfunction or failure of the product may reasonably be expected to result in significant injury to the user, without the express written approval of NYQUEST.

Revision History

<i>Version</i>	<i>Date</i>	<i>Description</i>	<i>Modified Page</i>
1.0	2014/08/29	Formal release.	-
1.1	2014/11/26	<ol style="list-style-type: none">1. Modify Table 9 Summary of Pad I/O Feature.2. Modify the description of IR Carrier.3. Modify WDT Time Base.4. Modify the description of Oscillation Configuration.5. Modify Figure 18 Four Operating Modes.6. Modify SUBIA Command.7. Add examples to Instruction Set.	<p>29</p> <p>38</p> <p>39, 66</p> <p>41</p> <p>43</p> <p>49, 63</p> <p>48-65</p>

Table of Contents

1. 概述	6
1.1 功能.....	6
1. General Description	8
1.1 Features.....	8
1.2 Block Diagram.....	10
1.3 Pin Assignment.....	10
1.4 Pin Description.....	11
2. Memory Organization	12
2.1 Program Memory.....	12
2.2 Data Memory.....	13
3. Function Description	16
3.1 R-page Special Function Register.....	16
3.1.1 <i>INDF (Indirect Addressing Register)</i>	16
3.1.2 <i>TMR0 (Timer0 Register)</i>	16
3.1.3 <i>PCL (Low Byte of PC[9:0])</i>	16
3.1.4 <i>STATUS (Status Register)</i>	17
3.1.5 <i>FSR (Register File Selection Register)</i>	17
3.1.6 <i>PortB (PortB Data Register)</i>	18
3.1.7 <i>PCON (Power Control Register)</i>	18
3.1.8 <i>BWUCON (PortB Wakeup Control Register)</i>	18
3.1.9 <i>PCHBUF (High Byte of PC)</i>	19
3.1.10 <i>BPLCON (PortB Pull-Low Resistor Control Register)</i>	19
3.1.11 <i>BPHCON (PortB Pull-High Resistor Control Register)</i>	19
3.1.12 <i>INTE (Interrupt Enable Register)</i>	19
3.1.13 <i>INTF (Interrupt Flag Register)</i>	20
3.2 T0MD Register.....	21
3.3 F-page Special Function Register.....	22
3.3.1 <i>IOSTB (PortB I/O Control Register)</i>	22
3.3.2 <i>PS0CV (Prescaler0 Counter Value Register)</i>	22
3.3.3 <i>BODCON (PortB Open-Drain Control Register)</i>	22
3.3.4 <i>PCON1 (Power Control Register1)</i>	23
3.4 S-page Special Function Register.....	23

3.4.1	TMR1 (Timer1 Register).....	23
3.4.2	T1CR1 (Timer1 Control Register1)	23
3.4.3	T1CR2 (Timer1 Control Register2)	24
3.4.4	PWM1DUTY (PWM1 Duty Register).....	25
3.4.5	PS1CV (Prescaler1 Counter Value Register)	25
3.4.6	BZ1CR (Buzzer1 Control Register).....	25
3.4.7	IRCR (IR Control)	26
3.4.8	TBHP (Table Access High Byte Address Pointer Register).....	27
3.4.9	TBHD (Table Access High Byte Data Register).....	27
3.4.10	OSCCR (Oscillation Control Register)	28
3.5	I/O Port.....	28
3.5.1	BLOCK DIAGRAM OF IO PINS	30
3.6	Timer0.....	34
3.7	Timer1/PWM1/Buzzer1	35
3.8	IR Carrier.....	38
3.9	Watch-Dog Timer (WDT).....	39
3.10	Interrupt.....	39
3.10.1	Timer0 Overflow Interrupt.....	40
3.10.2	Timer1 Underflow Interrupt.....	40
3.10.3	WDT Timeout Interrupt.....	40
3.10.4	PB Input Change Interrupt.....	40
3.10.5	External Interrupt.....	40
3.11	Oscillation Configuration	41
3.12	Operating Mode	43
3.12.1	Normal Mode	44
3.12.2	Slow Mode.....	44
3.12.3	Standby Mode	44
3.12.4	Halt Mode	45
3.12.5	Wakeup Stable Time	45
3.12.6	Summary of Operating Mode	46
3.13	Reset Process.....	46
4.	Instruction Set.....	48
5.	Configuration Words	66
6.	Electrical Characteristics	67
6.1	Absolute Maximum Rating.....	67

6.2	DC Characteristics	67
6.3	AC Characteristics.....	68
6.4	Characteristic Graph	69
6.4.1	<i>Frequency vs. VDD of I_HRC</i>	69
6.4.2	<i>Frequency vs. Temperature of I_HRC</i>	69
6.4.3	<i>Frequency vs. VDD of I_LRC</i>	70
6.4.4	<i>Frequency vs. Temperature of I_LRC</i>	70
6.5	Recommended Operating Voltage.....	71
6.6	LVR vs. Temperature	71
7.	DIE PAD Diagram	72
8.	Package Dimension	72
8.1	6-Pin Plastic SOT23-6 (63 mil)	72
8.2	8-Pin Plastic SOP (150 mil)	73
8.3	8-Pin Plastic DIP (300 mil).....	73
9.	Ordering Information	74

1. 概述

NY8A051A是以EPROM作為記憶體的 8 位元微控制器，專為家電或量測等等的I/O應用設計。採用CMOS製程並同時提供客戶低成本、高性能、及高抗電磁干擾等顯著優勢。NY8A051A核心建立在RISC精簡指令集架構可以很容易地做編輯和控制，共有 55 條指令。除了少數指令需要 2 個時序，大多數指令都是 1 個時序即能完成，可以讓使用者輕鬆地以程式控制完成不同的應用。因此非常適合各種中低記憶容量但又複雜的應用。

在I/O的資源方面，NY8A051A有 6 根彈性的雙向I/O腳，每個I/O腳都有單獨的暫存器控制為輸入或輸出腳。而且每一個I/O腳位都有附加的程式控制功能如上拉或下拉電阻或open-drain輸出。此外針對紅外線遙控的產品方面，NY8A051A內建了可選擇頻率的大電流輸出紅外載波發射口，電流可在 3V供電時達到 340mA。

NY8A051A有兩組計時器，可用系統頻率當作一般的計時的應用或者從外部訊號觸發來計數。另外NY8A051A提供 1 組 8 位元解析度的PWM輸出或者蜂鳴器輸出，可用來驅動馬達、LED、或蜂鳴器等等。

NY8A051A採用雙時鐘機制，高速振盪或者低速振盪都可以分別選擇內部RC振盪或外部Crystal輸入。在雙時鐘機制下，NY8A051A可選擇多種工作模式如一般模式(Normal)、慢速模式(Slow mode)、備用模式(Standby mode)與待機模式(Halt mode)可節省電力消耗延長電池壽命。並且微控制器在使用內部RC高速振盪時，低速振盪可以同時使用外部精準的Crystal計時。可以維持高速處理同時又能精準計算真實時間。

在省電的模式下如備用模式(Standby mode)與待機模式(Halt mode)中，有多種事件可以觸發中斷喚醒NY8A051A進入一般操作模式(Normal)或慢速模式(Slow mode)來處理突發事件。

1.1 功能

- 寬廣的工作電壓，CPU執行 4 個週期指令模式下：
 - 2.0V ~ 5.5V 系統頻率可選 32K、455K、1M、2M、4M 或 8MHz。
 - 2.2V ~ 5.5V 系統頻率可選 16M或 20MHz。
- 寬廣的工作溫度：-40°C ~ 85°C。
- 超過±8KV的ESD。
- 雜訊過濾功能打開時可容忍超過±4KV的EFT。(操作電壓@5V)
- 1Kx14 bits EPROM。
- 48 bytes SRAM。
- 6 根可分別單獨控制輸出輸入方向的I/O腳(GPIO)、PB[5:0]。
- PB[3:0]可選擇輸入時使用內建下拉電阻。
- PB[5:4]及PB[2:0]可選擇上拉電阻或開漏極輸出。
- PB[3]可選擇當作輸入或開漏極輸出。
- 8 層程式堆棧(Stack)。
- 存取資料有直接或間接定址模式。
- 一組 8 位元上數計時器(Timer0)包含可程式化的頻率預除線路。

- 一組 8 位元下數計時器(Timer1)可選重複載入或連續下數計時。
- 一個蜂鳴器輸出(BZ1)。
- 38/57KHz紅外線載波頻率可供選擇，同時載波之極性也可以根據數據作選擇。
- 大電流輸出紅外線載波發射口，可選一般或 340mA灌電流。
- 內建上電復位電路(POR)。
- 內建低壓復位功能(LVR)。
- 內建看門狗計時(WDT)，可由程式韌體控制開關。
- 雙時鐘機制，系統可以隨時切換高速振盪或者低速振盪。
 - 高速振盪: E_HXT(超過 6MHz外部高速石英振盪)
E_XT(455K~6MHz外部石英振盪)
I_HRC(1~20MHz內部高速RC振盪)
 - 低速振盪: E_LXT(32KHz外部低速石英振盪)
I_LRC(內部 32KHz低速RC振盪)
- 四種工作模式可隨系統需求調整電流消耗：一般模式(Normal)、慢速模式(Slow mode)、備用模式(Standby mode) 與待機模式(Halt mode)。
- 五種硬體中斷：
 - Timer0 溢位中斷。
 - Timer1 借位中斷。
 - WDT 中斷。
 - PB 輸入狀態改變中斷。
 - 外部中斷輸入。
- NY8A051A在備用模式(Standby mode)下的五種喚醒中斷：
 - Timer0 溢位中斷。
 - Timer1 借位中斷。
 - WDT 中斷。
 - PB 輸入狀態改變中斷。
 - 外部中斷輸入。
- NY8A051A在待機模式(Halt mode)下的三種喚醒中斷：
 - WDT 中斷。
 - PB 輸入狀態改變中斷。
 - 外部中斷輸入。

1. General Description

NY8A051A is an EPROM based 8-bit MCU tailored for I/O based applications like home appliances or meter equipment. NY8A051A adopts advanced CMOS technology to provide customers remarkable solution with low cost, high performance and high noise immunity benefits. RISC architecture is applied to NY8A051A and it provides 55 instructions. All instructions are executed in single instruction cycle except program branch and skip instructions which will take two instruction cycles. Therefore, NY8A051A is very suitable for those applications that are sophisticated but compact program size is required.

As NY8A051A address I/O type applications, it can provide 6 I/O pins for applications which require abundant input and output functionality. Moreover, each I/O pin may have additional features, like Pull-High/Pull-Low resistor and open-drain output type through programming. Moreover, NY8A051A have built-in large infrared (IR) carrier generator (340mA@3V) with selectable IR carrier frequency and polarity for applications which demand remote control feature.

NY8A051A also provide 2 sets of timers which can be used as regular timer based on system oscillation or event counter with external trigger clock. Moreover, NY8A051A provide 1 set of 8-bit resolution Pulse Width Modulation (PWM) output and buzzer output in order to drive motor/LED and buzzer.

NY8A051A employ dual-clock oscillation mechanism, either high oscillation or low oscillation can be derived from internal resistor/capacitor oscillator or external crystal oscillator. Moreover, based on dual-clock mechanism, NY8A051A provide kinds of operation mode like Normal mode, Slow mode, Standby mode and Halt mode in order to save power consumption and lengthen battery operation life. Moreover, it is possible to use internal high-frequency oscillator as CPU operating clock source and external 32KHz crystal oscillator as timer clock input, so as to accurate count real time and maintain CPU working power.

While NY8A051A operate in Standby mode and Halt mode, kinds of event will issue interrupt requests and can wakeup NY8A051A to enter Normal mode and Slow mode in order to process urgent events.

1.1 Features

- Wide operating voltage range: (@4 clock CPU cycle)
 - 2.0V ~ 5.5V @ system clock is 32K, 455K, 1M, 2M, 4M or 8MHz.
 - 2.2V ~ 5.5V @ system clock is 16M or 20MHz.
- Wide operating temperature: -40 °C ~ 85 °C.
- High ESD over ±8KV.
- High EFT over ±4KV with Noise Filter Enable. (Operating voltage @5v)
- 1Kx14 bits EPROM.
- 48 bytes SRAM.
- 6 general purpose I/O pins (GPIO), PB[5:0], with independent direction control.

- PB[3:0] has features of Pull-Low resistor for input pin.
- PB[5:4] and PB[2:0] have features of Pull-High resistor, and open-drain output
- PB[3] have feature of input or open-drain output
- 8-level hardware Stack.
- Direct and indirect addressing modes for data access.
- One 8-bit up-count timer (Timer0) with programmable prescaler.
- One 8-bit reload or continuous down-count timers (Timer1).
- One 8-bit resolution PWM (PWM1) output.
- One buzzer (BZ1) output.
- Selectable 38/57KHz IR carrier frequency and high/low polarity according to data value.
- IR carrier sink current can be normal sink current or 340mA large sink current.
- Built-in Power-On Reset (POR).
- Built-in Low-Voltage Reset (LVR).
- Built-in Watch-Dog Timer (WDT) enabled/disabled by firmware control.
- Dual-clock oscillation: System clock can switch between high oscillation and low oscillation.
 - High oscillation: E_HXT (External High Crystal Oscillator, 6MHz or above)
E_XT (External Crystal Oscillator, 455K~6MHz)
I_HRC (Internal High Resistor/Capacitor Oscillator ranging from 1M~20MHz)
 - Low oscillation: E_LXT (External Low Crystal Oscillator, about 32KHz)
I_LRC (Internal 32KHz oscillator)
- Four kinds of operation mode to reduce system power consumption:
 - Normal mode, Slow mode, Standby mode and Halt mode.
- Five hardware interrupt events:
 - Timer0 overflow interrupt.
 - Timer1 underflow interrupt.
 - WDT timeout interrupt.
 - PB input change interrupt.
 - External interrupt.
- Five interrupt events to wakeup NY8A051A from Standby mode:
 - Timer0 overflow interrupt.
 - Timer1 underflow interrupt.
 - WDT timeout interrupt.
 - PB input change interrupt.
 - External interrupt.

- Three interrupt events to wakeup NY8A051A from Halt mode:
 - WDT timeout interrupt.
 - PB input change interrupt.
 - External interrupt.

1.2 Block Diagram

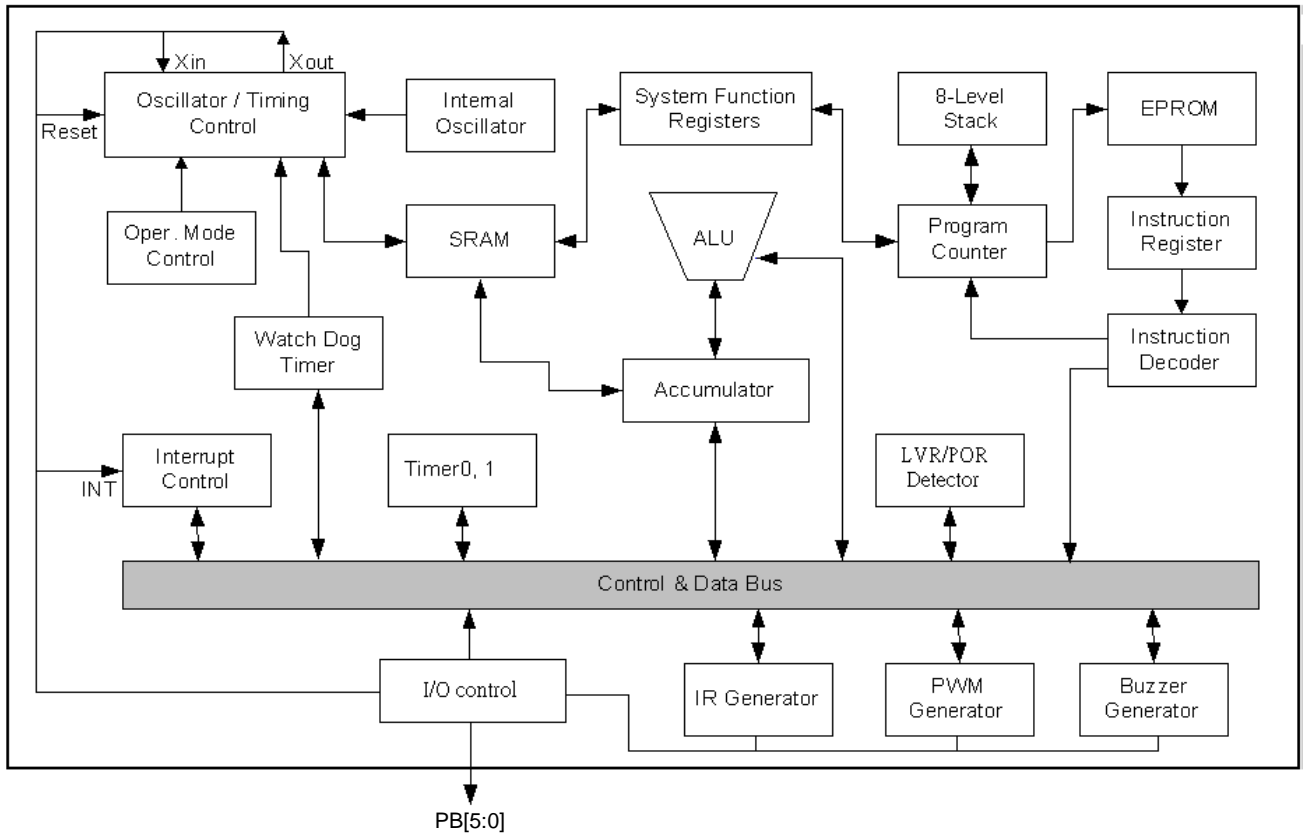

1.3 Pin Assignment

NY8A051A provide three kinds of package type which are SOP8, DIP8 and SOT23-6.



Figure 1 Package pin assignment

1.4 Pin Description

Pin Name	I/O	Description
PB0/INT/SDI	I/O	PB0 is a bidirectional I/O pin. PB0 is input pin of external interrupt when EIS=1 & INTIE=1. PB0 can be programming pad SDI.
PB1/IR/SDO	I/O	PB1 is a bidirectional I/O pin. If IR mode is enabled, this pin is IR carrier output with normal or large sink current. PB1 can be programming pad SDO.
PB2 / EX_CK1 / PWM1 / BZ1/SCK	I/O	PB2 is a bidirectional I/O pin. It can also be timer clock source EX_CK1. It can also be PWM output. It can also be BUZZER output. PB2 can be programming pad SCK.
PB3/RSTb/VPP	I/O	PB3 is an input pin or open-drain output pin. It can be reset pin RSTb. If RSTb pin is low, it will reset NY8A051A. If this pin is more than 8.5V, it also can make NY8A051A enter EPROM programming mode.
PB4/Xout	I/O	PB4 is a bidirectional I/O pin if I_HRC or I_LRC is adopted. PB4 also can be output of instruction clock. PB4 is output of external crystal if E_HXT, E_XT or E_LXT is adopted.
PB5/Xin	I/O	PB5 is a bidirectional I/O pin if I_HRC or I_LRC is adopted. PB5 is input of external crystal if E_HXT, E_XT or E_LXT is adopted.
VDD	-	Positive power supply.
VSS	-	Ground.

2. Memory Organization

NY8A051A memory divided into two categories: one is program memory and the other is data memory.

2.1 Program Memory

The program memory space of NY8A051A is 1K words. Therefore, the Program Counter (PC) is 10-bit wide in order to address any location of program memory.

Some locations of program memory are reserved as interrupt entrance. Power-On Reset vector is located at 0x000. Software interrupt vector is located at 0x001. Internal and external hardware interrupt vector is located at 0x008. Reserved vector is located at 0x00E & 0x00F.

NY8A051A provides instruction CALL, GOTOA, CALLA to address 256 location of program space. NY8A051A provides instruction GOTO to address 512 location of program space. NY8A051A also provides instructions LCALL and LGOTO to address any location of program space.

When a call or interrupt is happening, next ROM address is written to top of the stack, when RET, RETIA or RETIE instruction is executed, the top of stack data is read and load to PC.

NY8A051A program ROM address 0x00E~0x00F and 0x3FE~0x3FF are reserved space, if user tries to write code in these addresses will get unexpected false functions

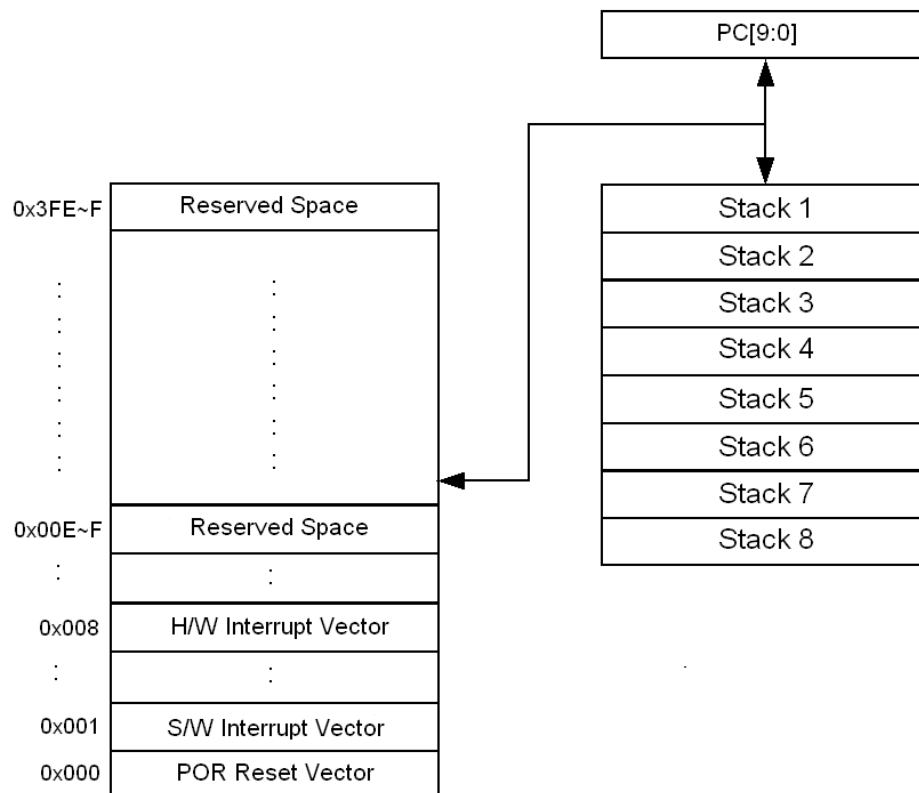

Figure 2 Program Memory Address Mapping

2.2 Data Memory

According to instructions used to access data memory, the data memory can be divided into three kinds of categories: one is R-page Special-function register (SFR) + General Purpose Register (GPR), another is F-page SFR and the other is S-page SFR. GPR are made of SRAM and user can use them to store variables or intermediate results.

R-page data memory is divided into 4 banks and can be accessed directly or indirectly through a SFR register which is File Select Register (FSR). FSR[7:6] are used as Bank register BK[1:0] to select one bank out of the 4 banks.

R-page register can be divided into addressing mode: direct addressing mode and indirect addressing mode.

The indirect addressing mode of data memory access is described in the following graph. This indirect addressing mode is implied by accessing register INDF. The bank selection is determined by FSR[7:6] and the location selection is from FSR[5:0].

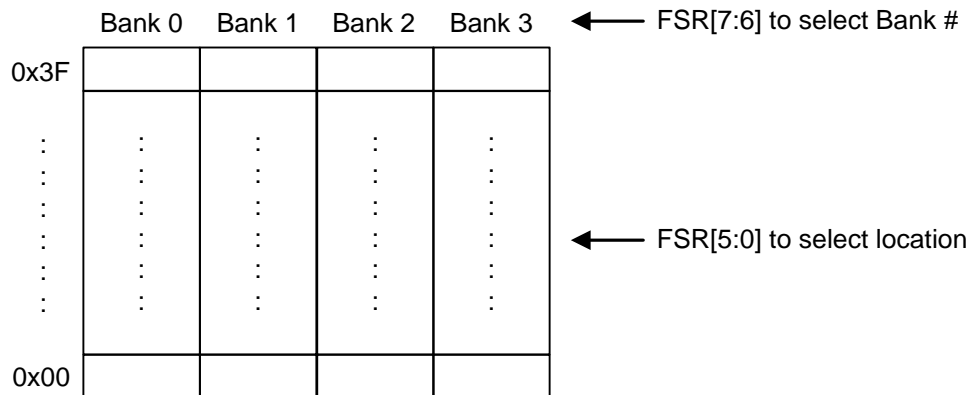

Figure 3 Indirect Addressing Mode of Data Memory Access

The direct addressing mode of data memory access is described below. The bank selection is determined by FSR[7:6] and the location selection is from instruction op-code[5:0] immediately.

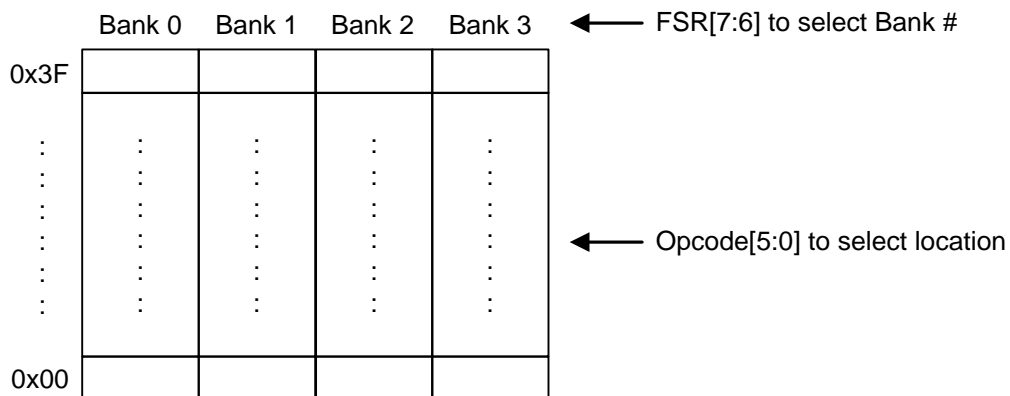

Figure 4 Direct Addressing Mode of Data Memory Access

R-page SFR can be accessed by general instructions like arithmetic instructions and data movement instructions. The R-page SFR occupy address from 0x0 to 0xF of Bank 0. However, the same address range of Bank 1, Bank 2 and Bank 3 are mapped back to Bank 0. In other words, R-page SFR physically existed at Bank 0. The GPR physically occupy address from 0x10 to 0x3F of Bank and other banks in address from 0x10 to 0x3F are mapped back as the Table 1 shows.

The NY8A051A register name and address mapping of R-page SFR are described in the following table.

FSR[7:6] Address	00 (Bank 0)	01 (Bank 1)	10 (Bank 2)	11 (Bank 3)
0x0	INDF	The same mapping as Bank 0		
0x1	TMR0			
0x2	PCL			
0x3	STATUS			
0x4	FSR			
0x5	-			
0x6	PORTB			
0x7	-			
0x8	PCON			
0x9	BWUCON			
0xA	PCHBUF			
0xB	BPLCON			
0xC	BPHCON			
0xD	-			
0xE	INTE			
0xF	INTF			
0x10 ~ 0x1F	General Purpose Register	Mapped to bank0		
0x20 ~ 0x3F	General Purpose Register	Mapped to bank0		

Table 1 R-page SFR Address Mapping

F-page SFR can be accessed only by instructions IOST and IOSTR. S-page SFR can be accessed only by instructions SFUN and SFUNR. FSR[7:6] bank select bits are ignored while F-page and S-page register is accessed. The register name and address mapping of F-page and S-page are depicted in the following table.

SFR Category Address	F-page SFR	S-page SFR
0x0	-	TMR1
0x1	-	T1CR1
0x2	-	T1CR2
0x3	-	PWM1DUTY
0x4	-	PS1CV
0x5	-	BZ1CR
0x6	IOSTB	IRCR
0x7	-	TBHP
0x8	-	TBHD
0x9	-	-
0xA	PS0CV	-
0xB	-	-
0xC	BODCON	-
0xD	-	-
0xE	-	-
0xF	PCON1	OSCCR

Table 2 F-page and S-page SFR Address Mapping

3. Function Description

This chapter will describe the detailed operations of NY8A051A.

3.1 R-page Special Function Register

3.1.1 INDF (Indirect Addressing Register)

Name	SFR Type	Addr.	Bit7	Bit6	Bit5	Bit4	Bit3	Bit2	Bit1	Bit0
INDF	R	0x0	INDF[7:0]							
R/W Property			R/W							
Initial Value			xxxxxxxx							

The register INDF is not physically existed and it is used as indirect addressing mode. Any instruction accessing INDF actually accesses the register pointed by register FSR.

3.1.2 TMR0 (Timer0 Register)

Name	SFR Type	Addr.	Bit7	Bit6	Bit5	Bit4	Bit3	Bit2	Bit1	Bit0
TMR0	R	0x1	TMR0[7:0]							
R/W Property			R/W							
Initial Value			xxxxxxxx							

When read the register TMR0, it actually read the current running value of Timer0.

Write to the register TMR0 will change the current value of Timer0.

Timer0 clock source can be from instruction clock F_{INST} or from external pin EX_CK1(PB2) or from Low Oscillator Frequency according to T0MD and configuration word setting.

3.1.3 PCL (Low Byte of PC[9:0])

Name	SFR Type	Addr.	Bit7	Bit6	Bit5	Bit4	Bit3	Bit2	Bit1	Bit0
PCL	R	0x2	PCL[7:0]							
R/W Property			R/W							
Initial Value			0x00							

The register PCL is the least significant byte (LSB) of 10-bit PC. PCL will be increased by one after one instruction is executed except some instructions which will change PC directly. The high byte of PC, i.e. PC[9:8], is not directly accessible. Update of PC[9:8] must be through register PCHBUF.

For GOTO instruction, PC[8:0] is from instruction word and PC[9] is loaded from PCHBUF[1]. For CALL instruction, PC[7:0] is from instruction word and PC[9:8] is loaded from PCHBUF[1:0]. Moreover the next PC address, i.e. PC+1, will push onto top of Stack. For LGOTO instruction, PC[9:0] is from instruction word.

For LCALL instruction, PC[9:0] is from instruction word. Moreover the next PC address, i.e. PC+1, will push onto top of Stack.

3.1.4 STATUS (Status Register)

Name	SFR Type	Addr.	Bit7	Bit6	Bit5	Bit4	Bit3	Bit2	Bit1	Bit0
STATUS	R	0x3	GP7	GP6	GP5	/TO	/PD	Z	DC	C
R/W Property			R/W	R/W	R/W	R/W(*2)	R/W(*1)	R/W	R/W	R/W
Initial Value			0	0	0	1	1	X	X	X

The register STATUS contains result of arithmetic instructions and reasons to cause reset.

C: Carry/Borrow bit

C=1, carry is occurred for addition instruction or borrow is not occurred for subtraction instruction.

C=0, carry is not occurred for addition instruction or borrow is occurred for subtraction instruction.

DC: Half Carry/Half Borrow bit

DC=1, carry from the 4th LSB is occurred for addition instruction or borrow from the 4th LSB is not occurred for subtraction instruction.

DC=0, carry from the 4th LSB is not occurred for addition instruction or borrow from the 4th LSB is occurred for subtraction instruction.

Z: Zero bit

Z=1, result of logical operation is zero.

Z=0, result of logical operation is not zero.

/PD: Power down flag bit

/PD=1, after power-up or after instruction CLRWDT is executed.

/PD=0, after instruction SLEEP is executed.

/TO: Time overflow flag bit

/TO=1, after power-up or after instruction CLRWDT or SLEEP is executed.

/TO=0, WDT timeout is occurred.

GP7, GP6, GP5: General purpose read/write register bit.

(*1) can be cleared by sleep instruction.

(*2) can be set by clrwtd instruction

3.1.5 FSR (Register File Selection Register)

Name	SFR Type	Addr.	Bit7	Bit6	Bit5	Bit4	Bit3	Bit2	Bit1	Bit0
FSR	R	0x4	BK[1:0]		FSR[5:0]					
R/W Property			R/W							
Initial Value			0	0	X	X	X	X	X	X

FSR[5:0]: Select one register out of 48 registers.

BK[1:0]: For NY8A051A, bank register is not used, because there's only one bank in NY8A051A.

3.1.6 PortB (PortB Data Register)

Name	SFR Type	Addr.	Bit7	Bit6	Bit5	Bit4	Bit3	Bit2	Bit1	Bit0
PortB	R	0x6	GP7	GP6	PB5	PB4	PB3	PB2	PB1	PB0
R/W Property			R/W							
Initial Value			Data latch value is xxxx, read value is xxxx port value(PB5~PB0)							

While reading PortB, it will get the status of pins of PB regardless that pin is configured as input or output pin. While writing to PortB, data is written to PB's data latch.

GP7, GP6: General purpose read/write register bit.

3.1.7 PCON (Power Control Register)

Name	SFR Type	Addr.	Bit7	Bit6	Bit5	Bit4	Bit3	Bit2	Bit1	Bit0
PCON	R	0x8	WDTEN	EIS	GP5	GP4	LVREN	GP2	GP1	GP0
R/W Property			R/W							
Initial Value			1	0	0	0	1	0	0	0

GP4~0: General read/write register bits.

LVREN: Enable/disable LVR.

LVREN=1, enable LVR.

LVREN=0, disable LVR.

EIS: Enable/disable INT.

EIS=1, PB0 is external interrupt.

EIS=0, PB0 is GPIO.

WDTEN: Enable/disable WDT.

WDTEN=1, enable WDT.

WDTEN=0, disable WDT.

3.1.8 BWUCON (PortB Wakeup Control Register)

Name	SFR Type	Addr.	Bit7	Bit6	Bit5	Bit4	Bit3	Bit2	Bit1	Bit0
BWUCON	R	0x9	-	-	WUPB5	WUPB4	WUPB3	WUPB2	WUPB1	WUPB0
R/W Property			-	-	R/W	R/W	R/W	R/W	R/W	R/W
Initial Value			X	X	1	1	1	1	1	1

WUPBx: Enable/disable PBx wakeup function, $0 \leq x \leq 5$.

WUPBx=1, enable PBx wakeup function.

WUPBx=0, disable PBx wakeup function.

3.1.9 PCHBUF (High Byte of PC)

Name	SFR Type	Addr.	Bit7	Bit6	Bit5	Bit4	Bit3	Bit2	Bit1	Bit0
PCHBUF	R	0xA	-	-	-	-	-	GP2	PCHBUF[1:0]	
R/W Property			-	-	-	-	-	R/W		
Initial Value			X	X	X	X	X	000		

PCHBUF[1:0]: Buffer of the 9th bit, 8th bit of PC.

GP2: General read/write register bit.

3.1.10 BPLCON (PortB Pull-Low Resistor Control Register)

Name	SFR Type	Addr.	Bit7	Bit6	Bit5	Bit4	Bit3	Bit2	Bit1	Bit0
BPLCON	R	-0xB	/PLPB3	/PLPB2	/PLPB1	/PLPB0	-	-	-	-
R/W Property			R/W	R/W	R/W	R/W	-	-	-	-
Initial Value			1	1	1	1	0	0	0	0

/PLPBx: Disable/enable PBx Pull-Low resistor, $0 \leq x \leq 3$.

/PLPBx=1, disable PBx Pull-Low resistor.

/PLPBx=0, enable PBx Pull-Low resistor.

3.1.11 BPHCON (PortB Pull-High Resistor Control Register)

Name	SFR Type	Addr.	Bit7	Bit6	Bit5	Bit4	Bit3	Bit2	Bit1	Bit0
BPHCON	R	0xC	-	-	/PHPB5(*1)	/PHPB4(*1)	GP3	/PHPB2	/PHPB1	/PHPB0
R/W Property			-	-	R/W	R/W	R/W	R/W	R/W	R/W
Initial Value			0	0	1	1	1	1	1	1

/PHPBx: Disable/enable PBx Pull-High resistor, $0 \leq x \leq 5$.

/PHPBx=1, disable PBx Pull-High resistor.

/PHPBx=0, enable PBx Pull-High resistor.

GP3: General read/write register bit.

Note: When PB4 and PB5 are used as crystal oscillator pads, the Pull-High resistor should not enable. Or the oscillation may fail.

3.1.12 INTE (Interrupt Enable Register)

Name	SFR Type	Addr.	Bit7	Bit6	Bit5	Bit4	Bit3	Bit2	Bit1	Bit0
INTE	R	0xE	-	WDTIE	-	-	T1IE	INTIE	PBIE	T0IE
R/W Property			-	R/W	-	-	R/W	R/W	R/W	R/W
Initial Value			X	0	X	X	0	0	0	0

T0IE: Timer0 overflow interrupt enable bit.

T0IE=1, enable Timer0 overflow interrupt.

T0IE=0, disable Timer0 overflow interrupt.

PBIE: PortB input change interrupt enable bit.

PBIE=1, enable PortB input change interrupt.

PBIE=0, disable PortB input change interrupt.

INTIE: External interrupt enable bit.

INTIE=1, enable external interrupt (PB0).

INTIE=0, disable external interrupt (PB0).

T1IE: Timer1 underflow interrupt enable bit.

T1IE=1, enable Timer1 underflow interrupt.

T1IE=0, disable Timer1 underflow interrupt.

WDTIE: WDT timeout interrupt enable bit.

WDTIE=1, enable WDT timeout interrupt.

WDTIE=0, disable WDT timeout interrupt.

3.1.13 INTF (Interrupt Flag Register)

Name	SFR Type	Addr.	Bit7	Bit6	Bit5	Bit4	Bit3	Bit2	Bit1	Bit0
INTF	R	0xF	-	WDTIF	-	-	T1IF	INTIF	PBIF	T0IF
R/W Property			-	R/W	-	-	R/W	R/W	R/W	R/W
Initial Value(note*)			0	0	0	0	0	0	0	0

T0IF: Timer0 overflow interrupt flag bit.

T0IF=1, Timer0 overflow interrupt is occurred.

T0IF must be clear by firmware.

PBIF: PortB input change interrupt flag bit.

PBIF=1, PortB input change interrupt is occurred.

PBIF must be clear by firmware.

INTIF: External interrupt flag bit.

INTIF=1, external interrupt is occurred.

INTIF must be clear by firmware.

T1IF: Timer1 underflow interrupt flag bit.

T1IF=1, Timer1 underflow interrupt is occurred.

T1IF must be clear by firmware.

WDTIF: WDT timeout interrupt flag bit.

WDTIF=1, WDT timeout interrupt is occurred.

WDTIF must be clear by firmware.

Note: When corresponding INTE bit is not enabled, the read interrupt flag is 0.

3.2 T0MD Register

T0MD is a read/write register which is only accessed by instruction T0MD.

Name	SFR Type	Addr.	Bit7	Bit6	Bit5	Bit4	Bit3	Bit2	Bit1	Bit0
T0MD	-	-	LCKTMO	INTEDG	T0CS	T0CE	PS0WDT	PS0SEL[2:0]		
R/W Property			R/W							
Initial Value(note*)			0	0	1	1	1	111		

PS0SEL[2:0]: Prescaler0 dividing rate selection. The rate depends on Prescaler0 is assigned to Timer0 or WDT. When Prescaler0 is assigned to WDT, the dividing rate is dependent on which timeout mechanism is selected.

PS0SEL[2:0]	Dividing Rate		
	PS0WDT=0 (Timer0)	PS0WDT=1 (WDT Reset)	PS0WDT=1 (WDT Interrupt)
000	1:2	1:1	1:2
001	1:4	1:2	1:4
010	1:8	1:4	1:8
011	1:16	1:8	1:16
100	1:32	1:16	1:32
101	1:64	1:32	1:64
110	1:128	1:64	1:128
111	1:256	1:128	1:256

Table 3 Prescaler0 Dividing Rate

PS0WDT: Prescaler0 assignment.

PS0WDT=1, Prescaler0 is assigned to WDT.

PS0WDT=0, Prescaler0 is assigned to Timer0.

Note: Always set PS0WDT and PS0SEL[2:0] before enabling watchdog or timer interrupt, or reset or interrupt may be falsely triggered.

T0CE: Timer0 external clock edge selection.

T0CE=1, Timer0 will increase one while high-to-low transition occurs on pin EX_CK1.

T0CE=0, Timer0 will increase one while low-to-high transition occurs on pin EX_CK1.

Note: T0CE is also applied to Low Oscillator Frequency as timer0 clock source condition

T0CS: Timer0 clock source selection.

T0CS=1, External clock pin EX_CK1 or Low Oscillator Frequency (I_LRC or E_LXT) is selected.

T0CS=0, Instruction clock F_{INST} is selected

INTEDG: Edge selection of external interrupt.

INTEDG=1, INTIF will be set while rising edge occurs on pin PB0.

INTEDG=0, INTIF will be set while falling edge occurs on pin PB0.

LCKTM0: When T0CS=1, timer 0 clock source can be optionally selected to be low-frequency oscillator.

T0CS=0, Instruction clock F_{INST} is selected as timer0 clock source.

T0CS=1, LCKTM0=0, external clock on pin EX_CK1 is selected as timer0 clock source.

T0CS=1, LCKTM0=1, Low Oscillator Frequency (I_LRC or E_LXT, depends on configuration word Low Oscillator Frequency) output replaces pin EX_CK1 as timer0 clock source.

Note: For more detail descriptions of timer0 clock source select, please see timer0 section.

3.3 F-page Special Function Register

3.3.1 IOSTB (PortB I/O Control Register)

Name	SFR Type	Addr.	Bit7	Bit6	Bit5	Bit4	Bit3	Bit2	Bit1	Bit0
IOSTB	F	0x6	GP7	GP6	IOPB5	IOPB4	IOPB3	IOPB2	IOPB1	IOPB0
R/W Property			R/W	R/W	R/W	R/W	R/W	R/W	R/W	R/W
Initial Value			0	0	1	1	1	1	1	1

IOPBx: PBx I/O mode selection, $0 \leq x \leq 5$.

IOPBx=1, PBx is input mode.

IOPBx=0, PBx is output mode.

GP7, GP6: General purpose register bit.

3.3.2 PS0CV (Prescaler0 Counter Value Register)

Name	SFR Type	Addr.	Bit7	Bit6	Bit5	Bit4	Bit3	Bit2	Bit1	Bit0
PS0CV	F	0xA	PS0CV[7:0]							
R/W Property			R							
Initial Value			1	1	1	1	1	1	1	1

While reading PS0CV, it will get current value of Prescaler0 counter.

3.3.3 BODCON (PortB Open-Drain Control Register)

Name	SFR Type	Addr.	Bit7	Bit6	Bit5	Bit4	Bit3	Bit2	Bit1	Bit0
BODCON	F	0xC	-	-	ODPB5	ODPB4	GP7	ODPB2	ODPB1	ODPB0
R/W Property			-	-	R/W	R/W	R/W	R/W	R/W	R/W
Initial Value			0	0	0	0	0	0	0	0

ODPBx: Enable/disable open-drain of PBx, $0 \leq x \leq 5$.

ODPBx=1, enable open-drain of PBx.

ODPBx=0, disable open-drain of PBx.

GP7: General purpose register bit.

3.3.4 PCON1 (Power Control Register1)

Name	SFR Type	Addr.	Bit7	Bit6	Bit5	Bit4	Bit3	Bit2	Bit1	Bit0
PCON1	F	0xF	GIE	-	GP5	GP4	GP3	GP2	GP1	T0EN
R/W Property			R/W(1*)	-	R/W	R/W	R/W	R/W	R/W	R/W
Initial Value			0	0	0	0	0	0	0	1

T0EN: Enable/disable Timer0.

T0EN=1, enable Timer0.

T0EN=0, disable Timer0.

GIE: Global interrupt enable bit.

GIE=1, enable all unmasked interrupts.

GIE=0, disable all interrupts.

GP1~5: General purpose read/write register.

(1*): set by instruction ENI, reset by instruction DISI, read by instruction IOSTR.

3.4 S-page Special Function Register

3.4.1 TMR1 (Timer1 Register)

Name	SFR Type	Addr.	Bit7	Bit6	Bit5	Bit4	Bit3	Bit2	Bit1	Bit0
TMR1	S	0x0	TMR1[7:0]							
R/W Property			R/W							
Initial Value			XXXXXXXX							

When reading register TMR1, it will obtain current value of 8-bit down-count Timer1. When writing register TMR1, it will both write data to timer1 reload register and update Timer1 current content.

3.4.2 T1CR1 (Timer1 Control Register1)

Name	SFR Type	Addr.	Bit7	Bit6	Bit5	Bit4	Bit3	Bit2	Bit1	Bit0
T1CR1	S	0x1	PWM1OEN	PWM1OAL	-	-	-	T1OS	T1RL	T1EN
R/W Property			W	W	-	-	-	R/W	R/W	R/W
Initial Value			0	0	X	X	X	0	0	0

This register is used to configure Timer1 functionality.

T1EN: Enable/disable Timer1.

T1EN=1, enable Timer1.

T1EN=0, disable Timer1.

T1RL: Configure Timer1 down-count mechanism while Non-Stop mode is selected (T1OS=0).

T1RL=1, initial value is reloaded from reload register TMR1.

T1RL=0, continuous down-count from 0xFF when underflow is occurred.

T1OS: Configure Timer1 operating mode while underflow is reached.

T1OS=1, One-Shot mode. Timer1 will count once from the initial value to 0x00.

T1OS=0, Non-Stop mode. Timer1 will keep down-count after underflow.

T1OS	T1RL	Timer1 Down-Count Functionality
0	0	Timer1 will count from reload value down to 0x00. When underflow is reached, 0xFF is reloaded and continues down-count.
0	1	Timer1 will count from reload value down to 0x00. When underflow is reached, reload value is reloaded and continues to down-count.
1	x	Timer1 will count from initial value down to 0x00. When underflow is reached, Timer1 will stop down-count.

Table 4 Timer1 Functionality

PWM1OAL: Define PWM1 output active state.

PWM1OAL=1, PWM1 output is active low.

PWM1OAL=0, PWM1 output is active high.

PWM1OEN: Enable/disable PWM1 output.

PWM1OEN=1, PWM1 output will be present on PB2.

PWM1OEN=0, PB2 is GPIO.

3.4.3 T1CR2 (Timer1 Control Register2)

Name	SFR Type	Addr.	Bit7	Bit6	Bit5	Bit4	Bit3	Bit2	Bit1	Bit0
T1CR2	S	0x2	-	-	T1CS	T1CE	/PS1EN	PS1SEL[2:0]		
R/W Property			-	-	R/W	R/W	R/W	R/W	R/W	R/W
Initial Value			X	X	1	1	1	1	1	1

This register is used to configure Timer1 functionality.

PS1SEL[2:0]: Prescaler1 dividing rate selection.

PS1SEL[2:0]	Dividing Rate
000	1:2
001	1:4
010	1:8
011	1:16
100	1:32
101	1:64
110	1:128
111	1:256

Table 5 Prescaler1 Dividing Rate

Note: Always set PS1SEL[2:0] at /PS1EN=1, or interrupt may be falsely triggered.

/PS1EN: Disable/enable Prescaler1.

/PS1EN=1, disable Prescaler1.

/PS1EN=0, enable Prescaler1.

T1CE: Timer1 external clock edge selection.

T1CE=1, Timer1 will decrease one while high-to-low transition occurs on pin EX_CK1.

T1CE=0, Timer1 will decrease one while low-to-high transition occurs on pin EX_CK1.

T1CS: Timer1 clock source selection.

T1CS=1, External clock on pin EX_CK1 is selected.

T1CS=0, Instruction clock is selected.

3.4.4 PWM1DUTY (PWM1 Duty Register)

Name	SFR Type	Addr.	Bit7	Bit6	Bit5	Bit4	Bit3	Bit2	Bit1	Bit0
PWM1DUTY	S	0x3	PWM1DUTY[7:0]							
R/W Property			W							
Initial Value			XXXXXXXX							

This register is write-only. After Timer1 is enabled and start down-count, PWM1 output will keep at inactive state. While Timer1 value is equal to PWM1DUTY, PWM1 output will become active state until underflow is occurred.

Moreover, the reload value of Timer1 stored on register TMR1 is used to define the PWM1 frame rate and register PWM1DUTY is used to define the duty cycle of PWM1.

3.4.5 PS1CV (Prescaler1 Counter Value Register)

Name	SFR Type	Addr.	Bit7	Bit6	Bit5	Bit4	Bit3	Bit2	Bit1	Bit0
PS1CV	S	0x4	PS1CV[7:0]							
R/W Property			R							
Initial Value			1	1	1	1	1	1	1	1

While reading PS1CV, it will get current value of Prescaler1 counter.

3.4.6 BZ1CR (Buzzer1 Control Register)

Name	SFR Type	Addr.	Bit7	Bit6	Bit5	Bit4	Bit3	Bit2	Bit1	Bit0
BZ1CR	S	0x5	BZ1EN	-	-	-	BZ1FSEL[3:0]			
R/W Property			W	-	-	-	W			
Initial Value			0	X	X	X	1	1	1	1

BZ1FSEL[3:0]: Frequency selection of BZ1 output.

BZ1FSEL[3:0]	BZ1 Frequency Selection	
	Clock Source	Dividing Rate
0000	Prescaler1 output	1:2
0001		1:4
0010		1:8
0011		1:16
0100		1:32
0101		1:64
0110		1:128
0111		1:256
1000	Timer1 output	Timer1 bit 0
1001		Timer1 bit 1
1010		Timer1 bit 2
1011		Timer1 bit 3
1100		Timer1 bit 4
1101		Timer1 bit 5
1110		Timer1 bit 6
1111		Timer1 bit 7

Table 6 Buzzer1 Output (PB2) Frequency Selection

BZ1 EN: Enable/Disable BZ1 output.

BZ1EN=1, enable Buzzer1.

BZ1EN=0, disable Buzzer1.

3.4.7 IRCR (IR Control)

Name	SFR Type	Addr.	Bit7	Bit6	Bit5	Bit4	Bit3	Bit2	Bit1	Bit0
IRCR	S	0x6	IROSC358M	-	-	-	-	IRCSEL	IRF57K	IREN
R/W Property			W	-	-	-	-	W	W	W
Initial Value			0	X	X	X	X	0	0	0

IREN: Enable/Disable IR carrier output.

IREN=1, enable IR carrier output.

IREN=0, disable IR carrier output.

IRF57K: Selection of IR carrier frequency.

IRF57K=1, IR carrier frequency is 57KHz.

IRF57K=0, IR carrier frequency is 38KHz.

IRCSEL: Polarity selection of IR carrier.

IRCSEL=0, IR carrier will be generated when I/O pin data is 1.

IRCSEL=1, IR carrier will be generated when I/O pin data is 0.

IROSC358M: When external crystal is used, this bit is determined according to what kind of crystal is used.

This bit is ignored if internal high frequency oscillation is used.

IROSC358M=1, crystal frequency is 3.58MHz.

IROSC358M=0, crystal frequency is 455 KHZ.

Note:

1. Only high oscillation (F_{Hosc}) (See section 3.11) can be used as IR clock source.
2. Division ration for different oscillation type.

Osc. Type	57KHz	38KHz	Conditions
High IRC(4MHz)	64	96	HIRC mode (the input to IR module is set to 4MHz no matter what system clock is)
Xtal 3.58MHz	64	96	Xtal mode & IROSC358M=1
Xtal 455KHz	8	12	Xtal mode & IROSC358M=1

Table 7 Division ration for different oscillation type

3.4.8 TBHP (Table Access High Byte Address Pointer Register)

Name	SFR Type	Addr.	Bit7	Bit6	Bit5	Bit4	Bit3	Bit2	Bit1	Bit0
TBHP	S	0x7	-	-	-	-	-	TBHP2	TBHP1	TBHP0
R/W Property			-	-	-	-	-	R/W	R/W	R/W
Initial Value			X	X	X	X	X	X	X	X

When instruction CALLA, GOTOA or TABLEA is executed, the target address is constituted by TBHP[2:0] and ACC. ACC is the Low Byte of PC[9:0] and TBHP[1:0] is the high byte of PC[9:0]. TBHP[2] is general register for NY8A051A,

3.4.9 TBHD (Table Access High Byte Data Register)

Name	SFR Type	Addr.	Bit7	Bit6	Bit5	Bit4	Bit3	Bit2	Bit1	Bit0
TBHD	S	0x8	--	--	TBHD5	TBHD4	TBHD3	TBHD2	TBHD1	TBHD0
R/W Property			--	--	R	R	R	R	R	R
Initial Value			X	X	X	X	X	X	X	X

When instruction TABLEA is executed, high byte of content of addressed ROM is loaded into TBHD[5:0] register. The Low Byte of content of addressed ROM is loaded to ACC.

3.4.10 OSCCR (Oscillation Control Register)

Name	SFR Type	Addr.	Bit7	Bit6	Bit5	Bit4	Bit3	Bit2	Bit1	Bit0
OSCCR	S	0xF	--	--	--	--	OPMD[1:0]		STPHOSC	SELHOSC
R/W Property			--	--	--	--	R/W		R/W	R/W
Initial Value			X	X	X	X	00		0	1

SELHOSC: Selection of system oscillation (F_{OSC}).

SELHOSC=1, F_{OSC} is high-frequency oscillation (F_{HOSC}).

SELHOSC=0, F_{OSC} is low-frequency oscillation (F_{LOSC}).

STPHOSC: Disable/enable high-frequency oscillation (F_{HOSC}).

STPHOSC=1, F_{HOSC} will stop oscillation and be disabled.

STPHOSC=0, F_{HOSC} keep oscillation.

OPMD[1:0]: Selection of operating mode.

OPMD[1:0]	Operating Mode
00	Normal mode
01	Halt mode
10	Standby mode
11	reserved

Table 8 Selection of Operating Mode by OPMD[1:0]

Note: *STPHOSC cannot be changed with SELHOSC or OPMD at the same time. STPHOSC cannot be changed with OPMD at the same time during SELHOSC=1.*

3.5 I/O Port

NY8A051A provide 6 I/O pins which are PB[5:0]. User can read/write these I/O pins through register PORTB. Each I/O pin has a corresponding register bit to define it is input pin or output pin. Register IOSTB[5:0] define the input/output direction of PB[5:0].

When an I/O pin is configured as input pin, it may have Pull-High resistor or Pull-Low resistor which is enabled or disabled through registers. Register BPHCON[5:0] are used to enable or disable Pull-High resistor of PB[5:0] except PB3. Register BPLCON[7:4] are used to enable or disable Pull-Low resistor of PB[3:0].

When an I/O pin is configured as output pin, there is a corresponding and individual register to select as Open-Drain output pin. Register BODCON[5:0] determine PB[5:0] is Open-Drain or not. (except PB[3], which is always in open-drain mode when configured as output port)

The summary of Pad I/O feature is listed in the table below.

Feature		PB[2:0]	PB[3]	PB[5:4]
Input	Pull-High Resistor	V	X	V
	Pull-Low Resistor	V	V	X
Output	Open-Drain	V	always	V

Table 9 Summary of Pad I/O Feature

The level change on each I/O pin of PB may generate interrupt request. Register BWUCON[5:0] will select which I/O pin of PB may generate this interrupt. As long as any pin of PB is selected by corresponding bit of BWUCON, the register bit PBIF (INTF[1]) will set to 1 if there is a level change occurred on any selected pin. An interrupt request will occur and interrupt service routine will be executed if register bit PBIE (INTE[1]) and GIE (PCON1[7]) are both set to 1.

There is one external interrupt provided by NY8A051A. When register bit EIS (PCON[6]) is set to 1, PB0 is used as input pin for external interrupt.

Note: When PB0 is both set as level change operation and external interrupt, the external interrupt will have higher priority, and the PB0 level change operation will be disabled. But PB5~PB1 level change function are not affected.

NY8A051A can provide IR carrier generation. IR carrier generation is enabled by register bit IREN (IRCR[0]) and carrier will be present on a PB1 pin. Mask option LARGEIR determines sink current value of IR carrier. When LARGEIR=1, the sink current=340mA, When LARGEIR=0, the sink current=60mA.

PB3 can be used as external reset input determined by a configuration word. When an active-low signal is applied to PB3, it will cause NY8A051A to enter reset process.

When external crystal (E_HXT, E_XT or E_LXT) is adopted for high oscillation or low oscillation according to setting of configuration words, PB5 will be used as crystal input pin (Xin) and PB4 will be used as crystal output pin (Xout).

When I_HRC or I_LRC mode is selected as system oscillation and E_HXT, E_XT or E_LXT is not adopted, instruction clock is observable on PB4 if a configuration word is enabled.

Moreover, PB2 can be timer 0 external clock source EX_CK1 if T0MD T0CS=1 and LCK_TM0=0. PB2 can be timer 1 external clock source if T1CS=1 and LCK_TM0=1.

Moreover, PB2 can be PWM output if T1CR1[7] PWM1OEN=1 and corresponding PB.2 configuration word. PB2 can also be Buzzer output if BZ1CR[7] BZ1EN=1 and corresponding PB.2 configuration word.

3.5.1 BLOCK DIAGRAM OF IO PINS

OD_EN: open-drain enable.

IO_SEL: set pad input or output.

WRITE_EN: write data to pad.

READ_EN: read pad to DATA_BUS.

PULLDOWN_EN: enable pull down.

PULLUP_ENB : enable pull high.

WUBx: wake up enable.

SET_PBIF: set port change interrupt flag.

EIS: Enable PortB INT.

T0CE: Choose Port High to Low or Low to High to trigger Timer.

EX_INT: External INT signal.

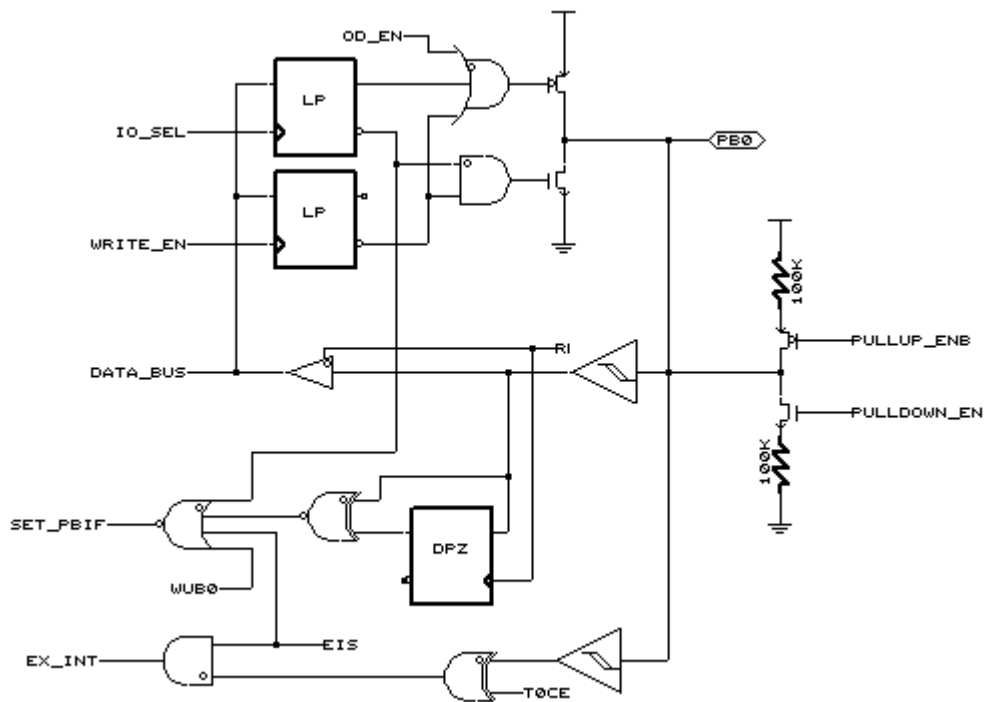

Figure 5 Block Diagram of PB0

- OD_EN: open-drain enable.
- IREN: Enable IR.
- IO_SEL: set pad input or output.
- WRITE_EN: write data to pad.
- READ_EN: read pad to DATA_BUS.
- PULLDOWN_EN: enable pull down.
- PULLUP_ENB : enable pull high.
- WUBx: wake up enable.
- SET_PBIF: set port change interrupt flag.

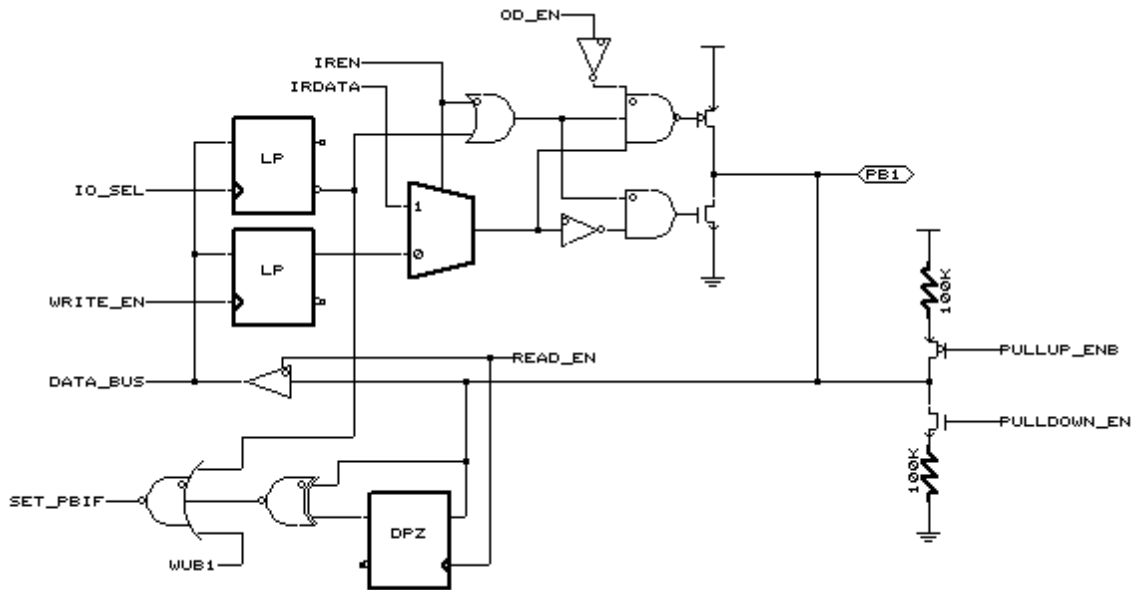

Figure 6 Block Diagram of PB1

- OD_EN: open-drain enable.
- IO_SEL: set pad input or output.
- WRITE_EN: write data to pad.
- READ_EN: read pad to DATA_BUS.
- PULLDOWN_EN: enable pull down.
- PULLUP_ENB : enable pull high.
- WUBx: wake up enable.
- SET_PBIF: set port change interrupt flag.
- T0_CKI: Timer0 EX CLOCK IN.
- PWMEN: PWM enable.
- BUZEN: BUZZER enable.
- PWM: PWM signal.
- BUZZER: BUZZER signal.

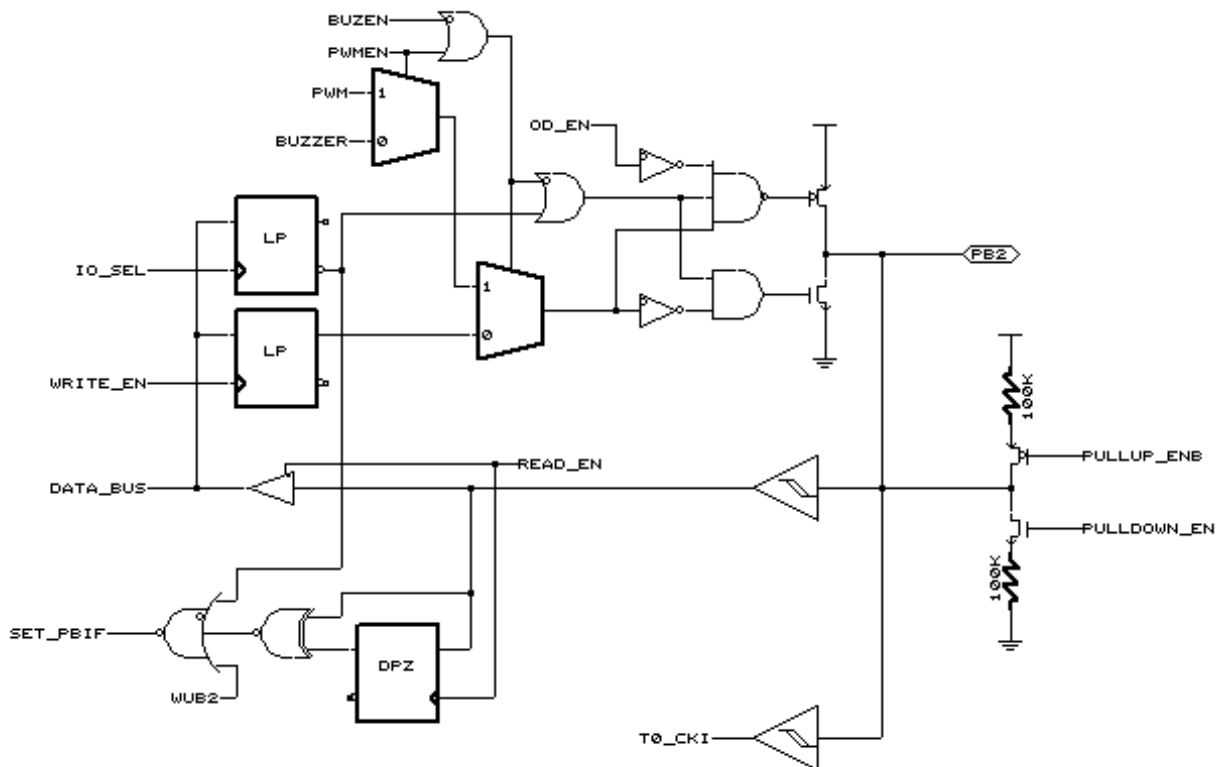

Figure 7 Block Diagram of PB2

PB3_RSTPAD: PB3 is set as Reset Pin by configuration word.

IO_SEL: set pad input or output.

WRITE_EN: write data to pad.

READ_EN: read pad to DATA_BUS.

PULLDOWN_EN: enable pull down.

WUBx: wake up enable.

SET_PBIF: set port change interrupt flag.

RSTB_IN: Reset signal with Schmitt trigger.

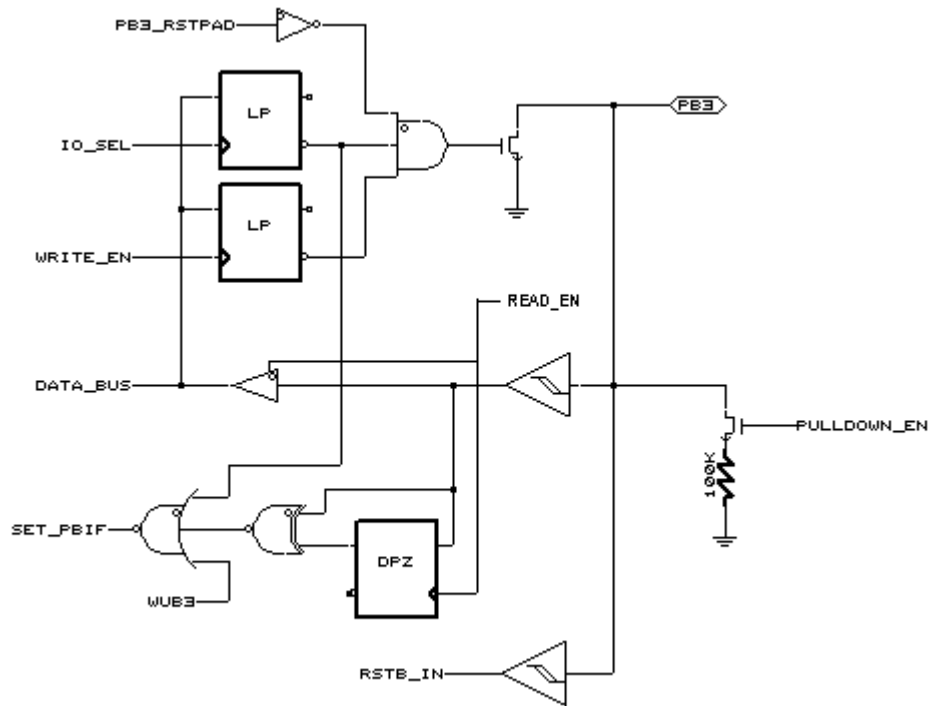

Figure 8 Block Diagram of PB3

- OD_EN: open-drain enable.
- XTL_EN: PB4, PB5 is set as Xtal Pin by configuration word.
- IO_SEL: set pad input or output.
- WRITE_EN: write data to pad.
- READ_EN: read pad to DATA_BUS.
- PULLUP_ENB : enable pull high.
- WUBx: wake up enable.
- SET_PBIF: set port change interrupt flag.

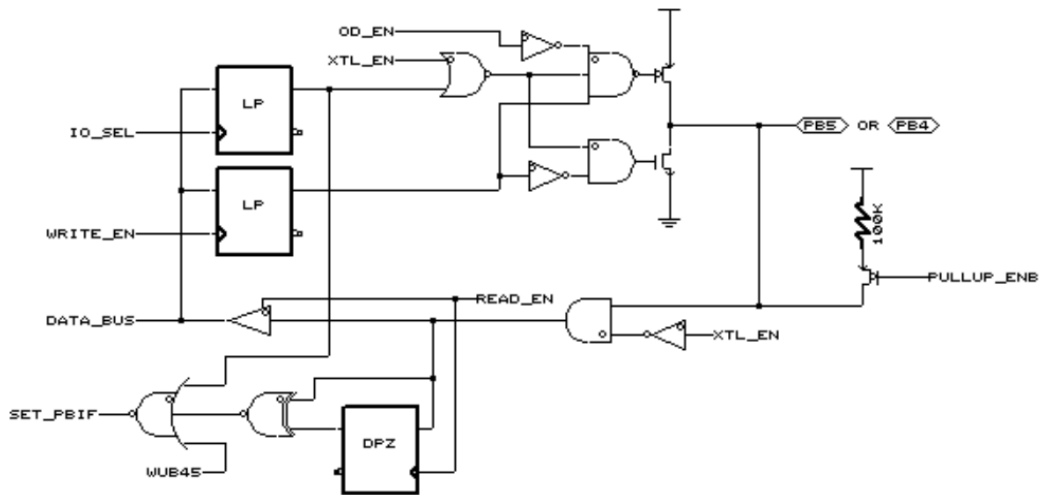

Figure 9 Block Diagram of PORT PB4/PB5

3.6 Timer0

Timer0 is an 8-bit up-count timer and its operation is enabled by register bit T0EN (PCON1[0]). Writing to Timer0 will set its initial value. Reading from Timer0 will show its current count value.

The clock source to Timer0 can be from instruction clock, external pin EX_CK1 or low speed clock Low Oscillator Frequency according to register bit T0CS and LCK_TM0 (T0MD[5] and T0MD[7]). When T0CS is 0, instruction clock is selected as Timer0 clock source. When T0CS is 1 and LCK_TM0 is 0, EX_CK1 is selected as Timer0 clock source. When T0CS is 1 and LCK_TM0 is 1 (and Timer0 source must set to 1), Low Oscillator Frequency (I_LRC or E_LXT, depends on configuration word) output is selected. Summarized table is shown below. (Also check Figure. 10)

Timer0 clock source	T0CS	LCKTM0	Timer0 source	Low Oscillator Frequency
Instruction clock	0	X	X	X
EX_CK1	1	0	X	X
		X	0	
E_LXT	1	1	1	1
I_LRC	1	1	1	0

Table 10 Summary of Timer0 clock source control

Moreover the active edge of EX_CKI or Low Oscillator Frequency to increase Timer0 can be selected by register bit T0CE (T0MD[4]). When T0CE is 1, high-to-low transition on EX_CKI or Low Oscillator Frequency will increase Timer0. When T0CE is 0, low-to-high transition on EX_CKI or Low Oscillator Frequency will increase Timer0. When using Low Oscillator Frequency as timer0 clock source, it is suggested to use prescaler0 (see below descriptions) and the ratio set to more than 4, or missing count may happen.

Before Timer0 clock source is supplied to Timer0, it can be divided by Prescaler0 if register bit PS0WDT (T0MD[3]) is clear to 0. When writing 0 to PS0WDT by instruction, Prescaler0 is assigned to Timer0 and Prescaler0 will be clear after this instruction is executed. The dividing rate of Prescaler0 is determined by register bits PS0SEL[2:0] which is from 1:2 to 1:256.

When Timer0 is overflow, the register bit T0IF (INTF[0]) will be set to 1 to indicate Timer0 overflow event is occurred. If register bit T0IE (INTE[0]) and GIE are both set to 1, interrupt request will occur and interrupt service routine will be executed. T0IF will not be clear until firmware writes 0 to T0IF.

The block diagram of Tmer0 and WDT is shown in the figure below.

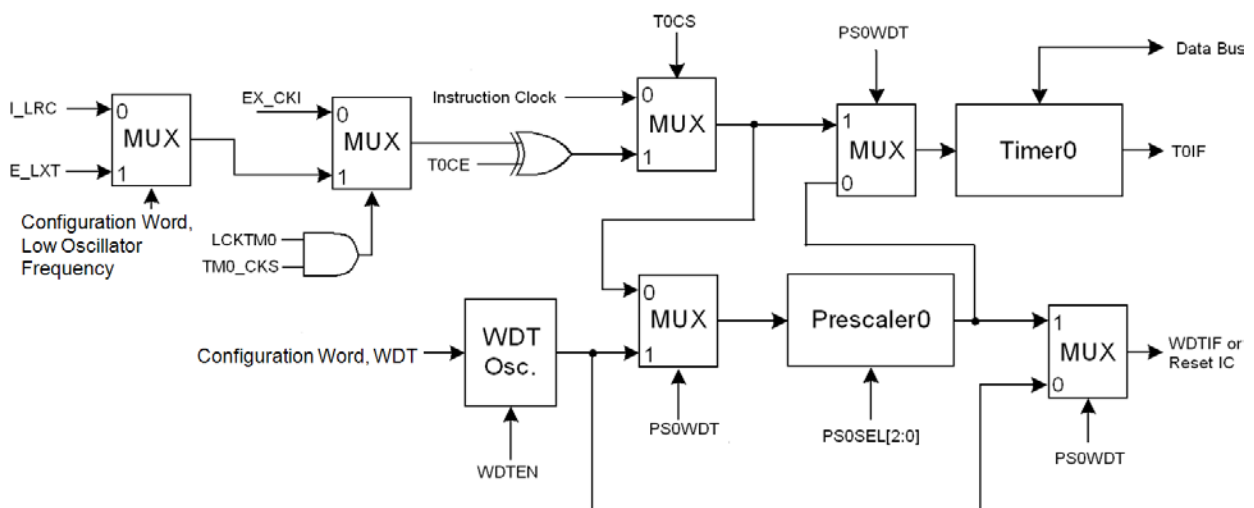

Figure 10 Block Diagram of Timer0 and WDT

3.7 Timer1/PWM1/Buzzer1

Timer1 is an 8-bit down-count timer with Prescaler1 whose diving rate is programmable. The output of Timer1 can be used to generate PWM1 output and Buzzer1 output. A write to the Timer1 will both write to a timer1 reload register (T1rld) and timer1 counter. A read to the timer1 will show the content of the Timer1 current count value.

The block diagram of Timer1 is shown in the figure below.

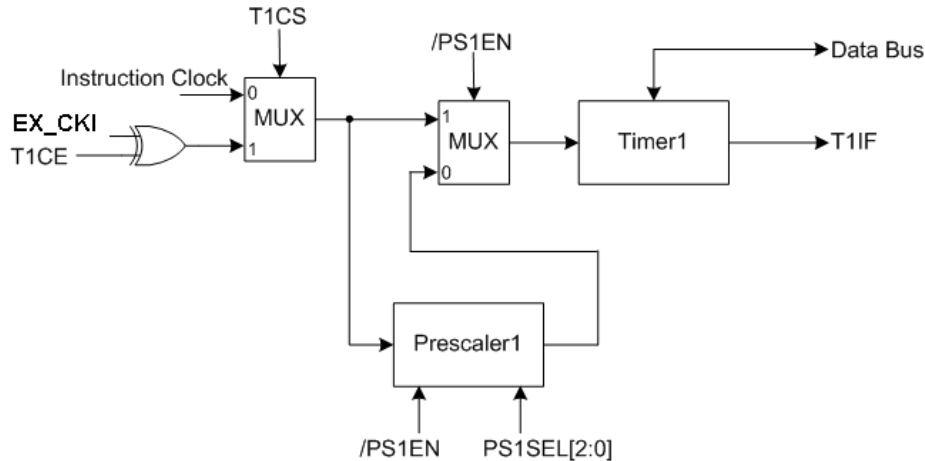

Figure 11 Block Diagram of Timer1

The operation of Timer1 can be enabled or disabled by register bit T1EN (T1CR1[0]). After Timer1 is enabled, its clock source can be instruction clock or pin EX_CKI which is determined by register bit T1CS (T1CR2[5]). When T1CS is 1, EX_CKI is selected as clock source. When T1CS is 0, instruction clock is selected as clock source. When EX_CKI is selected, the active edge to decrease Timer1 is determined by register bit T1CE (T1CR2[4]). When T1CE is 1, high-to-low transition on EX_CKI will decrease Timer1. When T1CE is 0, low-to-high transition on EX_CKI will decrease Timer1. The selected clock source can be divided further by Prescaler1 before it is applied to Timer1. Prescaler1 is enabled by writing 0 to register bit /PS1EN (T1CR2[3]) and the dividing rate is from 1:2 to 1:256 determined by register bits PS1SEL[2:0] (T1CR2[2:0]). Current value of Prescaler1 can be obtained by reading register PS1CV.

Timer1 provide two kinds of operating mode: one is One-Shot mode and the other is Non-Stop mode. When register bit T1OS (T1CR1[2]) is 1, One-Shot mode is selected. Timer1 will count down once from initial value stored on register TMR1 to 0x00, i.e. underflow is occurred. When register bit T1OS (T1CR1[2]) is 0, Non-Stop mode is selected. When underflow is occurred, there are two selections to start next down-count which is determined by register bit T1RL (T1CR1[1]). When T1RL is 1, the initial value stored on register TMR1 will be restored and start next down-count from this initial value. When T1RL is 0, Timer1 will start next down-count from 0xFF.

When Timer1 is underflow, the register bit T1IF (INTF[3]) will be set to 1 to indicate Timer1 underflow event is occurred. If register bit T1IE (INTE[3]) and GIE are both set to 1, interrupt request will occur and interrupt service routine will be executed. T1IF will not be clear until firmware writes 0 to T1IF.

The timing chart of Timer1 is shown in the following figure.

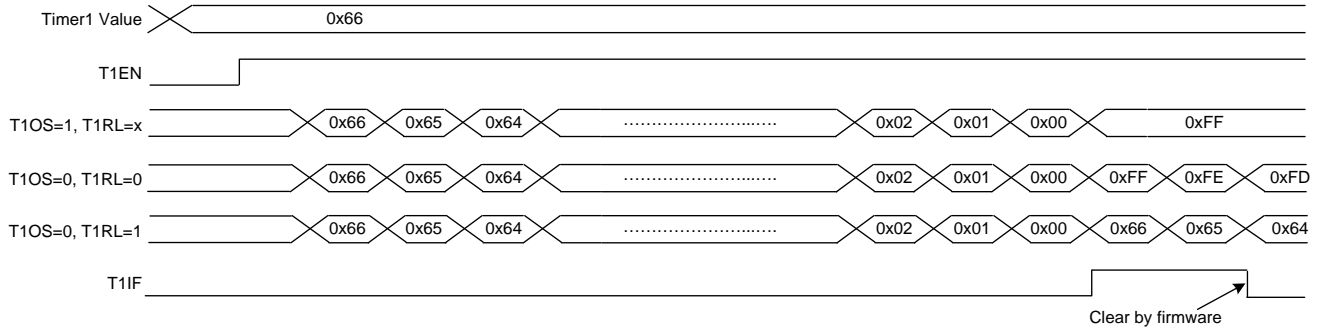

Figure 12 Timer1 Timing Chart

The PWM1 output can be available on I/O pin PB2 when register bit PWM1OEN (T1CR1[7]) is set to 1 and configuration word PB.2 is PWM. When PWM1OEN=1, PB2 will become output pin automatically. The active state of PWM1 output is determined by register bit PWM1OAL (T1CR1[6]). When PWM1OAL is 1, PWM1 output is active low. When PWM1OAL is 0, PWM1 output is active high. Moreover, the duty cycle and frame rate of PWM1 are both programmable. The duty cycle is determined by register PWM1DUTY. When PWM1DUTY is 0, PWM1 output will be never active. When PWM1DUTY is 0xFF, PWM1 output will be active for 255 Timer1 input clocks. The frame rate is determined by TMR1 initial value. Therefore, PWM1DUTY value must be less than or equal to TMR1. The block diagram of PWM1 is illustrated in the following figure.

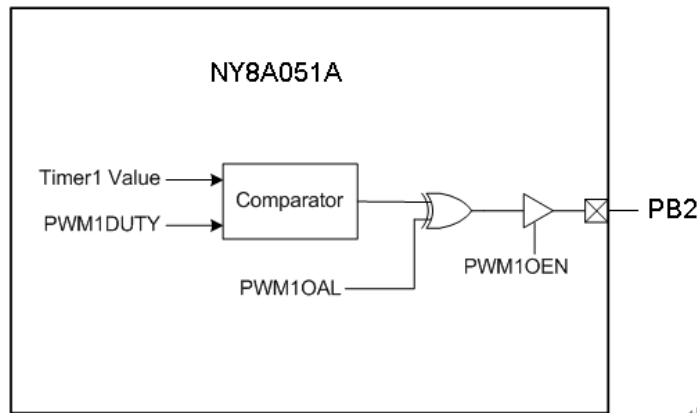

Figure 13 PWM1 Block Diagram

The Buzzer1 output (BZ1) can be available on I/O pin PB2 , when register bit BZ1EN (BZ1CR1[7]) is set to 1 and corresponding configuration word PB.2 is BUZZER. When BZ1EN is set to 1, PB2 will become output pin automatically. The frequency of BZ1 can be derived from Timer1 output or Prescaler1 output and dividing rate is determined by register bits BZ1FSEL[3:0] (BZ1CR[3:0]). When BZ1FSEL[3] is 0, Prescaler1 output is selected to generate BZ1 output. When BZ1FSEL[3] is 1, Timer1 output is selected to generate BZ1 output. The diving rate can be from 1:2 to 1:256 in order to generate all kinds of frequency. The diving rate can be from 1:2 to 1:256 in order to generate all kinds of frequency. The block diagram of Buzzer1 is illustrated in the following figure.

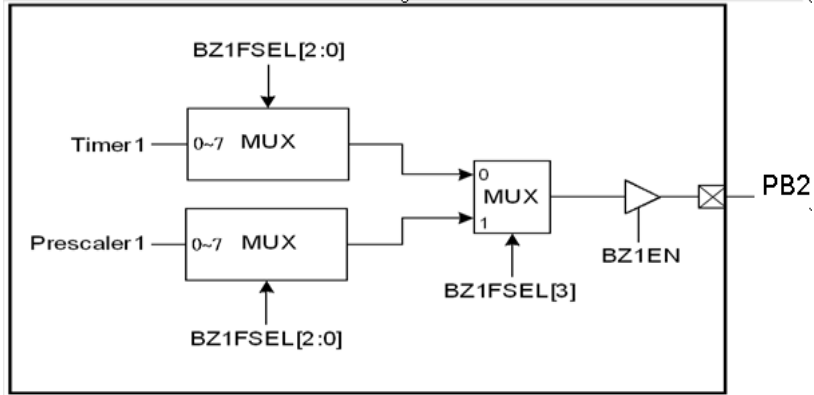

Figure 14 Buzzer1 Block Diagram

3.8 IR Carrier

NY8A051A provide two kinds of IR carrier according to its sink capability. One is Normal IR carrier whose sink current depends on how I/O pin (PB1) is configured. The other is Large IR carrier whose sink current is 340mA. This feature is determined by a configuration word. When Normal IR is selected, IR carrier will be preset on I/O pin PB1 with sink current 60mA. When Large IR is selected, IR carrier will be preset on I/O pin PB1 with sink current 340mA.

The IR carrier will be generated after register bit IREN (IRCR[0]) is set to 1. Moreover, PB1 will become output pin automatically. When IREN is clear to 0, PB1 will become general I/O pin as it was configured.

The IR carrier frequency is selectable by register bit IRF57K (IRCR[1]). When IRF57K is 1, IR carrier frequency is 57KHz. When IRF57K is 0, IR carrier frequency is 38KHz. Because IR carrier frequency is derived from high frequency system oscillation F_{HOSC} . Moreover, it is necessary to specify what frequency is used as system oscillation when external crystal is used. Register bit IROSC358M (IRCR[7]) is used to provide NY8A051A this information. When IROSC358M is 1, frequency of external crystal is 3.58MHz and when IROSC358M is 0, frequency of external crystal is 455KHz. When internal high frequency oscillation is adopted, this register will be ignored, and it will provide 4MHz clock to IR module.

The active state (polarity) of IR carrier is selectable according to PB1 output data. When register bit IRCSEL (IRCR[2]) is 1, IR carrier will be present on pin PB1 when its output data is 0. When register bit IRCSEL (IRCR[2]) is 0, IR carrier will be present on pin PB1 when its output data is 1. The polarity of IR carrier is shown in the following figure.

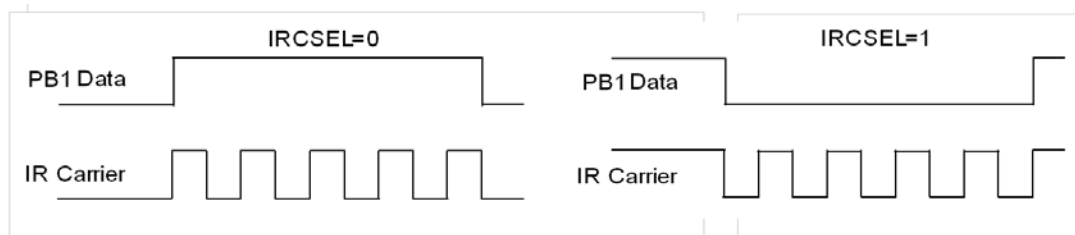

Figure 15 Polarity of IR Carrier vs. Output Data

3.9 Watch-Dog Timer (WDT)

There is an on-chip free-running oscillator in NY8A051A which is used by WDT. As this oscillator is independent of other oscillation circuits, WDT may still keep working during Standby mode and Halt mode.

WDT can be enabled or disabled by a configuration word. When WDT is enabled by configuration word, its operation still can be controlled by register bit WDTEN (PCON[7]) during program execution. Moreover, the mechanism after WDT time-out can reset NY8A051A or issue an interrupt request which is determined by another configuration word. At the same time, register bit /TO (STATUS[4]) will be clear to 0 after WDT time-out.

The baseline of WDT time-out period can be 3.5 ms, 15 ms, 60 ms or 250 ms which is determined by two configuration words. The time-out period can be lengthened if Prescaler0 is assigned to WDT. Prescaler0 will be assigned to WDT by writing 1 to register bit PS0WDT. The dividing rate of Prescaler0 for WDT is determined by register bits PS0SEL[2:0] and depends on WDT time-out mechanism. The dividing rate is from 1:1 to 1:128 if WDT time-out will reset NY8A051A and dividing rate is from 1:2 to 1:256 if WDT time-out will interrupt NY8A051A.

When Prescaler0 is assigned to WDT, the execution of instruction CLRWDT will clear WDT, Prescaler0 and set /TO flag to 1.

If user selects interrupt for WDT time-out mechanism, register bit WDTIF (INTF[6]) will set to 1 after WDT is expired. It may generate an interrupt request if register bit WDTIE (INTE[6]) and GIE both set to 1. WDTIF will not be clear until firmware writes 0 to WDTIF.

3.10 Interrupt

NY8A051A provide two kinds of interrupt: one is software interrupt and the other is hardware interrupt. Software interrupt is caused by execution of instruction INT. There are 5 hardware interrupts:

- Timer0 overflow interrupt,
- Timer1 underflow interrupt,
- WDT timeout interrupt,
- PB input change interrupt,
- External interrupt.

GIE is global interrupt enable flag. It has to be 1 to enable hardware interrupt functions. GIE can be set by ENI instruction and clear to 0 by DISI instruction.

After instruction INT is executed, no matter GIE is set or clear, the next instruction will be fetched from address 0x001. At the same time, GIE will be clear to 0 by NY8A051A automatically. This will prevent nested interrupt from happening. The last instruction of interrupt service routine of software interrupt has to be RETIE. Execution of this instruction will set GIE to 1 and return to original execution sequence.

While any of hardware interrupts is occurred, the corresponding bit of Interrupt Flag Register INTF will be set to 1. This bit will not be clear until firmware writes 0 to this bit. Therefore user can obtain information of which event causes hardware interrupt by polling register INTF. Note that only when the corresponding bit of Interrupt Enable Register INTE is set to 1, will the corresponding interrupt flag be read. And if the corresponding bit of Interrupt Enable Register INTE is set to 1 and GIE is also 1, hardware interrupt will occur and next instruction will be fetched from 0x008. At the same time, the register bit GIE will be clear by NY8A051A automatically. If user wants to implement nested interrupt, instruction ENI can be used as the first instruction of interrupt service routine which will set GIE to 1 again and allow other interrupt events to interrupt NY8A051A again. Instruction RETIE has to be the last instruction of interrupt service routine which will set GIE to 1 and return to original execution sequence.

It should be noted that ENI instruction cannot be placed right before RETIE instruction because ENI instruction in interrupt service routine will trigger nested interrupt, but RETIE will clear internal interrupt processing after jump out of ISR, so it is possible for interrupt flag to be falsely cleared

3.10.1 Timer0 Overflow Interrupt

Timer0 overflow (from 0x00 to 0xFF) will set register bit T0IF. This interrupt request will be serviced if T0IE and GIE are set to 1.

3.10.2 Timer1 Underflow Interrupt

Timer1 underflow (from 0xFF to 0x00) will set register bit T1IF. This interrupt request will be serviced if T1IE and GIE are set to 1.

3.10.3 WDT Timeout Interrupt

When WDT is timeout and the configuration word selects WDT timeout will generate interrupt request, it will set register bit WDTIF. This interrupt request will be serviced if WDTIE and GIE are set to 1.

3.10.4 PB Input Change Interrupt

When PBx, $0 \leq x \leq 5$, is configured as input pin and corresponding register bit WUPBx is set to 1, a level change on these selected I/O pin(s) will set register bit PBIF. This interrupt request will be serviced if PBIE and GIE are set to 1. Note when PB0 is both set as level change interrupt and external interrupt, the external interrupt flag EIS will disable PB0 level change operation.

3.10.5 External Interrupt

According to the configuration of EIS=1 and INTEDG, EIS and INTEDG, the selected active edge on I/O pin PB0 will set register bit INTIF. This interrupt request will be serviced if INTIE and GIE are set to 1.

3.11 Oscillation Configuration

Because NY8A051A is a dual-clock IC, there are high oscillation (F_{HOSC}) and low oscillation (F_{LOSC}) which can be selected as system oscillation (F_{OSC}). The oscillators which could be used as F_{HOSC} are internal high RC oscillator (I_HRC), external high crystal oscillator (E_HXT) and external crystal oscillator (E_XT). The oscillators which could be used as F_{LOSC} are internal low RC oscillator (I_LRC) and external low crystal oscillator (E_LXT).

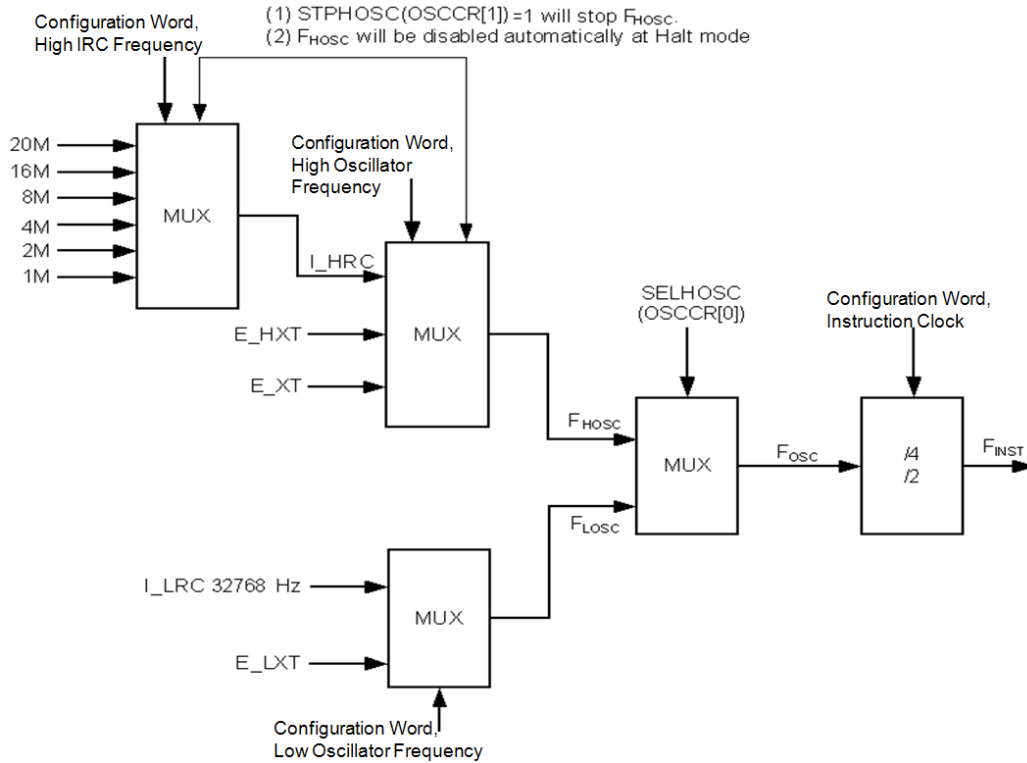

Figure 16 Oscillation Configuration of NY8A051A

There are two configuration words to determine which oscillator will be used as F_{HOSC} . When I_HRC is selected as F_{HOSC} , I_HRC output frequency is determined by three configuration words and it can be 1M, 2M, 4M, 8M, 16M or 20MHz. Moreover, external crystal oscillator pads PB4 and PB5 can be used as I/O pins. On the other hand, PB4 can be the output pin of instruction clock according to a configuration word's setting. If F_{HOSC} required external crystal whose frequency ranges from 6MHz to 20MHz, E_HXT is recommended. If F_{HOSC} required external crystal whose frequency ranges from 455KHz to 6MHz, E_XT is recommended. When E_HXT or E_XT is adopted, PB4/PB5 can not be used as I/O pins. They must be used as crystal output pin and input pin. PB4 is crystal output pin (Xout) and PB5 is crystal input pin (Xin).

There is one configuration word to determine which oscillator will be used as F_{LOSC} . When I_LRC is selected, its frequency is centered on 32768Hz. If F_{LOSC} required external crystal, E_LXT is selected and only 32768Hz crystal is allowed. When E_LXT is adopted, PB4/PB5 can not be used as I/O pins. They must be used as crystal output pin and input pin. PB4 is crystal output pin (Xout) and PB5 is crystal input pin (Xin). The dual-clock combination of F_{HOSC} and F_{LOSC} is listed below:

No.	FHOSC	FLOSC
1	I_HRC	I_LRC
2	E_HXT or E_XT	I_LRC
3	I_HRC	E_LXT

Table 11 Dual-clock combinations

When E_HXT, E_XT or E_LXT is used as one of oscillations, the crystal or resonator is connected to Xin and Xout to provide oscillation. Moreover, a resistor and two capacitors are recommended to connect as following figure in order to provide reliable oscillation. refer to the specification of crystal or resonator to adopt appropriate C1,C2 or RS value. The recommended value of C1 and C2 are listed in the Table12 below.

Oscillation Mode	Crystal Frequency(Hz)	C1, C2 (pF)
E_HXT	16M	5 ~ 10
	10M	5 ~ 30
	8M	5 ~ 20
E_XT	4M	5 ~ 30
	1M	5 ~ 30
	455K	10 ~ 100
E_LXT	32768	5 ~ 30

Table 1 Recommended R, C1 and C2 Value for Different Kinds of Crystal Oscillation

For 20MHz resonator in 2 clock CPU cycle mode, A 18pF C2 capacitor is a must.

Moreover, for precision 32.768k crystal, it is recommended to set C1=C2=15pF capacitor.

The accuracy of I_HRC is $\pm 1\%$ and accuracy of I_LRC is $\pm 5\%$ at 25°C commercial conditions.

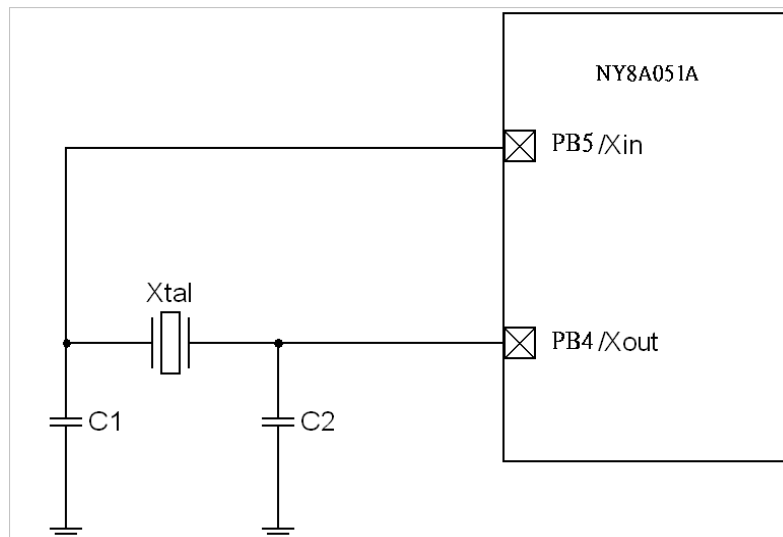

Figure 17 Connection for External Crystal Oscillation

Either F_{HOSC} or F_{LOSC} can be selected as system oscillation F_{OSC} according to the value of register bit SELHOSC (OSCCR[0]). When SELHOSC is 1, F_{HOSC} is selected as F_{OSC} . When SELHOSC is 0, F_{LOSC} is selected as F_{OSC} . Once F_{OSC} is determined, the instruction clock F_{INST} can be $F_{OSC}/2$ or $F_{OSC}/4$ according to value of a configuration word.

3.12 Operating Mode

NY8A051A provide four kinds of operating mode to tailor all kinds of application and save power consumptions. These operating modes are Normal mode, Slow mode, Standby mode and Halt mode. Normal mode is designated for high-speed operating mode. Slow mode is designated for low-speed mode in order to save power consumption. At Standby mode, NY8A051A will stop almost all operations except Timer0/Timer1/WDT in order to wakeup periodically. At Halt mode, NY8A051A will sleep until external event or WDT trigger IC to wakeup.

The block diagram of four operating modes is described in the following figure.

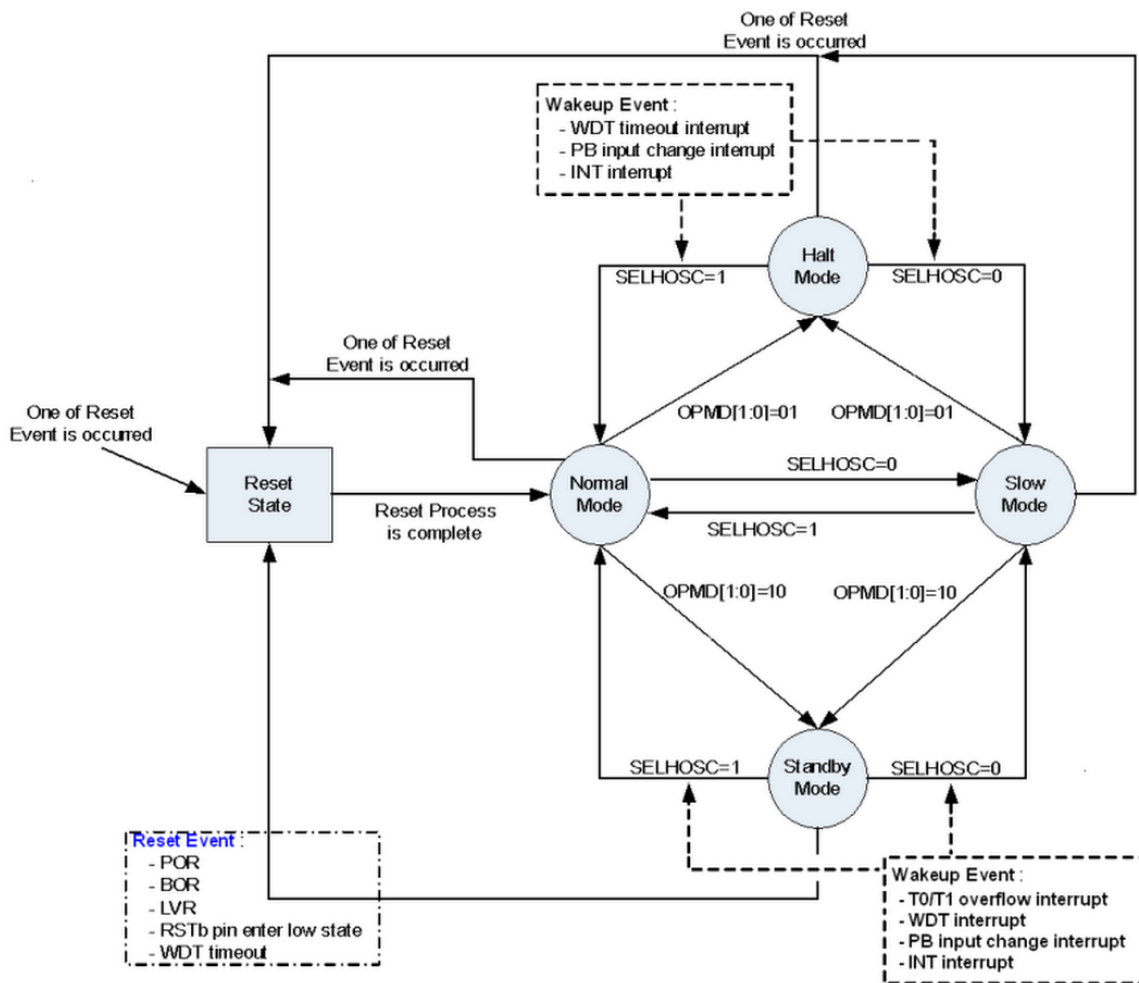

Figure 18 Four Operating Modes

3.12.1 Normal Mode

After any Reset Event is occurred and Reset Process is complete, NY8A051A will enter Normal mode. At Normal mode, F_{HOSC} is selected as system oscillation in order to provide highest performance and its power consumption will be the largest among four operating modes. After power on or any reset trigger is released, NY8A051A will enter Normal mode after reset process is complete.

- Instruction execution is based on F_{HOSC} and all peripheral modules may be active according to corresponding module enable bit.
- The F_{LOSC} is still active and running.
- IC can switch to Slow mode by writing 0 to register bit SELHOSC (OSCCR[0]).
- IC can switch to Standby mode or Halt mode by programming register bits OPMD[1:0] (OSCCR[3:2]).
- For real time clock applications, the NY8A051A can run in normal mode, at the same time the low-frequency clock. Low Oscillator Frequency connects to timer0 clock. This is made possible by setting LCKTM0 to 1 and corresponding configuration word Timer0 source setting to 1.

3.12.2 Slow Mode

NY8A051A will enter Slow mode by writing 0 to register bit SELHOSC. At Slow mode, F_{LOSC} is selected as system oscillation in order to save power consumption but still keep IC running. However, F_{HOSC} will not be disabled automatically by NY8A051A. Therefore user can write 0 to register bit STPHOSC (OSCCR[1]) in slow mode to reduce power consumption further. But it is noted that it is forbidden to enter slow mode and stop F_{HOSC} at the same time, one must enter slow mode first, then disable F_{HOSC} , or the program may hang on.

- Instruction execution is based on F_{LOSC} and all peripheral modules may be active according to corresponding module enable bit.
- F_{HOSC} can be disabled by writing 1 to register bit STPHOSC.
- IC can switch to Standby mode or Halt mode by programming register bits OPMD[1:0].
- IC can switch to Normal mode by writing 1 to SELHOSC.

3.12.3 Standby Mode

NY8A051A will enter Standby mode by writing 10b to register bits OPMD[1:0]. At Standby mode, however, F_{HOSC} will not be disabled automatically by NY8A051A and user has to enter slow mode and write 1 to register bit STPHOSC in order to stop F_{HOSC} oscillation. Most of NY8A051A peripheral modules are disabled but Timer can be still active if register bit T0EN/T1EN is set to 1. Therefore NY8A051A can wakeup after Timer0/Timer1 is expired. The expiration period is determined by the register TMR0, F_{INST} and other configurations for Timer0/Timer1.

- Instruction execution is stop and some peripheral modules may be active according to corresponding module enable bit.
- F_{HOSC} can be disabled by writing 1 to register bit STPHOSC.

- The F_{LOSC} is still active and running.
- IC can wakeup from Standby mode if any of (a) Timer0/Timer1 overflow interrupt, (b) WDT timeout interrupt, (c) PB input change interrupt or (d) INT external interrupt is happened.
- After wakeup from Standby mode, IC will return to Normal mode if SELHOSC=1, IC will return to Slow mode if SELHOSC=0.

It is not recommended to change oscillator mode (normal to slow / slow to normal) and enter standby mode at the same time.

3.12.4 Halt Mode

NY8A051A will enter Halt mode by executing instruction SLEEP or writing 01b to register bits OPMD[1:0]. After entering Halt mode, register bit /PD (STATUS[3]) will be clear to 0, register bit /TO (STATUS[4]) will be set to 1 and WDT will be clear but keep running.

At Halt mode, all of peripheral modules are disabled, instruction execution is stop and NY8A051A can only wakeup by some specific events. Therefore, Halt mode is the most power saving mode provided by NY8A051A.

- Instruction execution is stop and all peripheral modules are disabled.
- F_{HOSC} and F_{LOSC} are both disabled automatically.
- IC can wakeup from Halt mode if any of (a) WDT timeout interrupt, (b) PB input change interrupt or (c) INT or external interrupt is happened.
- After wakeup from Halt mode, IC will return to Normal mode if SELHOSC=1, IC will return to Slow mode if SELHOSC=0.

Note: you can change SELHOSC and enter Halt mode in the same instruction.

- It is not recommended to change oscillator mode (normal to slow / slow to normal) and enter standby mode at the same time

3.12.5 Wakeup Stable Time

The wakeup stable time of Halt mode is determined by a configuration word High Oscillator Frequency or Low Oscillator Frequency. If one of E_HXT, E_XT and E_LXT is selected, the wakeup period would be $512 \cdot F_{OSC}$. And if no XT mode are selected, $16 \cdot F_{osc}$ would be set as wake up period. On the other hand, there is no need of wakeup stable time for Standby mode because either F_{HOSC} or F_{LOSC} is still running at Standby mode.

Before NY8A051A enter Standby mode or Halt mode, user may write 1 to register bit GIE or execute instruction ENI. At this condition, NY8A051A will branch to address 0x008 in order to execute interrupt service routine after wakeup. If instruction DISI is executed or 0 is written to register bit GIE before entering Standby mode or Halt mode, the next instruction will be executed after wakeup.

3.12.6 Summary of Operating Mode

The summary of four operating modes is described in the following table.

Mode	Normal	Slow	Standby	Halt
F _{HOSC}	Enabled	STPHOSC	STPHOSC	Disabled
F _{LOSC}	Enabled	Enabled	Enabled	Disabled
Instruction Execution	Executing	Executing	Stop	Stop
Timer0	T0EN	T0EN	T0EN	Disabled
WDT	Option and WDTEN	Option and WDTEN	Option and WDTEN	Option and WDTEN
Other Modules	Module enable bit	Module enable bit	All disabled	All disabled
Wakeup Source	-	-	- Timer0 overflow - Timer1 overflow - WDT timeout - PB input change - INT	- WDT timeout - PB input change - INT

Table 13 Summary of Operating Modes

3.13 Reset Process

NY8A051A will enter Reset State and start Reset Process when one of following Reset Event is occurred:

- Power-On Reset (POR) is occurred when VDD rising is detected.
- Low-Voltage Reset (LVR) is occurred when operating VDD is below pre-defined voltage.
- Pin RSTb is low state.
- WDT timeout reset.

Moreover, value of all registers will be initialized to their initial value or unchanged if its initial value is unknown. The status bits /TO and /PD could be initialized according to which event causes reset. The /TO and /PD value and its associated event is summarized in the table below.

Event	/TO	/PD
POR, BOR, LVR	1	1
RSTb reset from non-Halt mode	unchanged	unchanged
RSTb reset from Halt mode	1	0
WDT reset from non-Halt mode	0	1
WDT reset from Halt mode	0	0
SLEEP executed	1	0
CLRWDW executed	1	1

Table 14 Summary of /TO & /PD Value and its Associated Event

After Reset Event is released, NY8A051A will start Reset Process. It will wait certain amount of period for oscillation stable no matter what kind of oscillator is adopted. This period is called power-up reset time and is determined by two-bit configuration words which can be 18ms, 72ms or 288ms. After oscillator is stable, NY8A051A will wait further 16 clock cycles of F_{HOSC} (oscillator start-up time, OST) and Reset Process is complete.

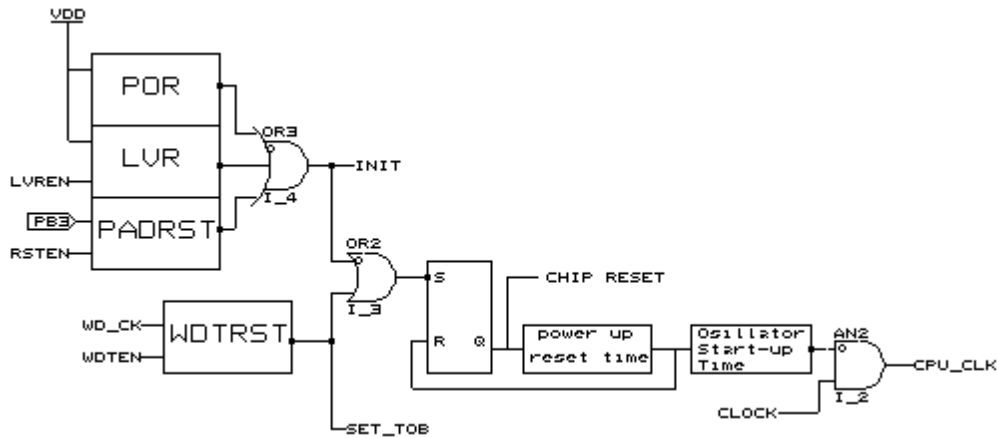

Figure 19 Block diagram of on-chip reset circuit

For slow VDD power-up, it is recommended to use RSTb reset, as the following figure.

- It is recommended the R value should be not greater than 40K Ohm.
- The R1 value=100 Ohm to 1K will prevent high current, ESD or Electrical overstress flowing into reset pin.
- The diode helps discharge quickly when power down.

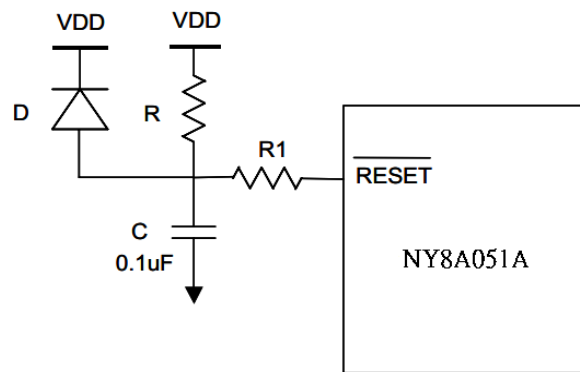

Figure 20 Block Diagram of reset application

4. Instruction Set

NY8A051A provide 55 powerful instructions for all kinds of applications. These instructions are listed in the following table.

Mnemonic	Description	Operation	Length	Cycle	Status Affected
NOP	No operation	No operation	1	1	-
SLEEP	Go into Halt mode	00h → WDT, 00h → WDT prescaler 1 → /TO, 0 → /PD	1	1	/TO, /PD
CLRWDT	Clear Watch-Dog Timer	00h → WDT, 00 → WDT prescaler 1 → /TO, 1 → /PD	1	1	/TO, /PD
T0MD	Load ACC to T0MD	ACC → T0MD	1	1	-
ENI	Enable interrupt	Enable Interrupt	1	1	-
IOST F	Load ACC to F-page SFR	ACC → F-page SFR	1	1	-
RET	Return from subroutine	Top of Stack → PC	1	2	-
RETIE	Return from interrupt and enable interrupt	Top of Stack → PC 1 → GIE	1	2	-
DAA	Decimal adjust for ACC	ACC(hex) → ACC(dec)	1	1	C
DISI	Disable interrupt	Disable Interrupt	1	1	-
T0MDR	Move T0MD to ACC	T0MD → ACC	1	1	-
IOSTR F	Move F-page SFR to ACC	F-page SFR → ACC	1	1	-
SFUN S	Load ACC to S-page SFR	ACC → S-page SFR	1	1	-
SFUNR S	Move S-page SFR to ACC	S-page SFR → ACC	1	1	-
MOVAR R	Move ACC to R	ACC → R	1	1	-
MOVR R, d	Move R	R → dest	1	1	Z
CLRA	Clear ACC	00h → ACC, 1 → Z	1	1	Z
INT	Interrupt	PC + 1 → Top of Stack, 001h → PC	1	3	-
TABLEA	Read ROM data to TBHD and ACC	ROM data { TBHP, ACC } [7:0] → ACC ROM data { TBHP, ACC } [13:8] → TBHD.	1	2	-
CALLA	Call subroutine	PC + 1 → Top of Stack. { TBHP, ACC } → PC	1	2	-
GOTOA	Unconditional branch	{ TBHP, ACC } → PC	1	2	-
CLRR R	Clear R	00h → R, 1 → Z	1	1	Z

Mnemonic	Description	Operation	Length	Cycle	Status Affected
ADDAR R, d	Add ACC and R	$ACC + R \rightarrow dest$	1	1	Z, DC, C
SUBAR R, d	Subtract ACC from R	$R - ACC \rightarrow dest$	1	1	Z, DC, C
INCR R, d	Increase R	$R + 1 \rightarrow dest$	1	1	Z
DECR R, d	Decrease R	$R - 1 \rightarrow dest$	1	1	Z
COMR R, d	Complement R	$\sim R \rightarrow dest$	1	1	Z
ANDAR R, d	AND ACC with R	$ACC \& R \rightarrow dest$	1	1	Z
IORAR R, d	OR ACC with R	$ACC R \rightarrow dest$	1	1	Z
XORAR R, d	Exclusive-OR ACC with R	$ACC \oplus R \rightarrow dest$	1	1	Z
RRR R, d	Rotate right R	$C \rightarrow dest[7],$ $R[7:1] \rightarrow dest[6:0],$ $R[0] \rightarrow C$	1	1	C
RLR R, d	Rotate left R	$R[7] \rightarrow C,$ $R[6:0] \rightarrow dest[7:1],$ $C \rightarrow dest[0]$	1	1	C
SWAPR R, d	Swap halves R	$R[3:0] \rightarrow dest[7:4].$ $R[7:4] \rightarrow dest[3:0]$	1	1	-
INCRSZ R, d	Increase R, Skip if 0	$R + 1 \rightarrow dest,$ Skip if result = 0	1	1 or 2(skip)	-
DECRSZ R, d	Decrease R, Skip if 0	$R - 1 \rightarrow dest,$ Skip if result = 0	1	1/2	-
RETIA i	Return, Place immediate in ACC	$i \rightarrow ACC,$ Top of Stack $\rightarrow PC$	1	2	-
MOVIA i	Move immediate to ACC	$i \rightarrow ACC$	1	1	-
ANDIA i	AND immediate with ACC	$ACC \& i \rightarrow ACC$	1	1	Z
IORIA i	OR immediate with ACC	$ACC i \rightarrow ACC$	1	1	Z
XORIA i	Exclusive-OR immediate with ACC	$ACC \oplus i \rightarrow ACC$	1	1	Z
ADDIA i	Add ACC and immediate	$ACC + i \rightarrow ACC$	1	1	Z, DC, C
ADCIA i	Add ACC and immediate with Carry	$ACC + i + C \rightarrow ACC$	1	1	Z, DC, C
SUBIA i	Subtract ACC from immediate	$i - ACC \rightarrow ACC$	1	1	Z, DC, C
SBCIA i	Subtract ACC and Carry from immediate	$i + (\sim ACC) + C \rightarrow ACC$	1	1	Z, DC, C
CALL i	Call subroutine	$PC + 1 \rightarrow Top\ of\ Stack,$ {PCHBUF, i} $\rightarrow PC$	1	2	-
GOTO i	Unconditional branch	{PCHBUF, i} $\rightarrow PC$	1	2	-
ADCAR R, d	Add ACC and R with Carry	$R + ACC + C \rightarrow ACC$	1	1	Z, DC, C
SBCAR R, d	Subtract ACC and Carry from R	$R + (\sim ACC) + C \rightarrow dest$	1	1	Z, DC, C

Mnemonic	Description	Operation	Length	Cycle	Status Affected
CMPAR R	Compare R with ACC	$R - ACC \rightarrow$ (No restore)	1	1	Z, C
BCR R, bit	Clear bit in R	$0 \rightarrow R[\text{bit}]$	1	1	-
BSR R, bit	Set bit in R	$1 \rightarrow R[\text{bit}]$	1	1	-
BTRSC R, bit	Test bit in R and skip if clear	Skip next instruction, if $R[\text{bit}] = 0$	1	1 or 2(skip)	-
BTRSS R, bit	Test bit in R and skip if set	Skip next instruction, if $R[\text{bit}] = 1$	1	1 or 2(skip)	-
LCALL i	Call subroutine	$PC + 1 \rightarrow$ Top of Stack; $i \rightarrow PC[10:0]$	1	2	-
LGOTO i	Unconditional branch	$i \rightarrow C[10:0]$	1	2	-

Table 25 Instruction Set

R: R-page SFR, R is 0x00 ~0x3F.

F: F-page SFR, F is 0x5 ~ 0xF.

S: S-page SFR, S is 0x0 ~ 0xF.

ACC: Accumulator.

i: 8-bit immediate data or 10 bit immediate address.

d: Destination

If d is "0", the result is stored in the ACC.

If d is "1", the result is stored back in register R.

Bit: Bit address within an 8-bit register R.

GIE: Global interrupt enable bit.

T0MD: T0MD register.

PD: Power down flag.

TO: Time overflow bit.

IOST: I/O port control register.

Z: Zero flag.

C: Carry flag.

DC: Digital carry flag.

WDT: Watchdog Timer Counter.

Prescaler: Prescaler0 dividing rate.

dest: Destination.

PC: Program Counter.

PCHBUF: High Byte Buffer of Program Counter.

TBHP: The high-Byte at target address.

TBHD: Store the high-Byte data at target address in ROM.

ADCAR	Add ACC and R with Carry
Syntax:	ADCAR R, d
Operand:	$0 \leq R \leq 63$ d = 0, 1.
Operation:	$R + ACC + C \rightarrow ACC$
Status affected:	Z, DC, C
Description:	Add the contents of ACC and register R with Carry. If d is 0, the result is stored in ACC. If d is 1, the result is stored back to R.
Cycle	1
Example:	ADCAR R, d before executing instruction: ACC=0x12, R=0x34, C=1, d=1, after executing instruction: R=0x47, ACC=0x12, C=0.

ADDAR	Add ACC and R
Syntax:	ADDAR R, d
Operand:	$0 \leq R \leq 63$ d = 0, 1.
Operation:	$ACC + R \rightarrow dest$
Status affected:	Z, DC, C
Description:	Add the contents of ACC and R. If d is 0, the result is stored in ACC. If d is 1, the result is stored back to R.
Cycle:	1
Example:	ADDAR R, d before executing instruction: ACC=0x12, R=0x34, C=1, d=1, after executing instruction: R=0x46, ACC=0x12, C=0.

ADCIA	Add ACC and Immediate with Carry
Syntax:	ADCIA i
Operand:	$0 \leq i < 255$
Operation:	$ACC + i + C \rightarrow ACC$
Status affected:	Z, DC, C
Description:	Add the contents of ACC and the 8-bit immediate data i with Carry. The result is placed in ACC.
Cycle:	1
Example:	ADCIA i before executing instruction: ACC=0x12, i=0x34, C=1, after executing instruction: ACC=0x47, C=0.

ADDIA	Add ACC and Immediate
Syntax:	ADDIA i
Operand:	$0 \leq i < 255$
Operation:	$ACC + i \rightarrow ACC$
Status affected:	Z, DC, C
Description:	Add the contents of ACC with the 8-bit immediate data i. The result is placed in ACC.
Cycle:	1
Example:	ADDIA i before executing instruction: ACC=0x12, i=0x34, C=1, after executing instruction: ACC=0x46, C=0.

ANDAR	AND ACC and R
Syntax:	ANDAR R, d
Operand:	$0 \leq R \leq 63$ $d = 0, 1.$
Operation:	ACC & R \rightarrow dest
Status affected:	Z
Description:	The content of ACC is AND'ed with R. If d is 0, the result is stored in ACC. If d is 1, the result is stored back to R.
Cycle:	1
Example:	ANDAR R, d before executing instruction: ACC=0x5A, R=0xAF, d=1. after executing instruction: R=0x0A, ACC=0x5A, Z=0.

BCR	Clear Bit in R
Syntax:	BCR R, bit
Operand:	$0 \leq R \leq 63$ $0 \leq \text{bit} \leq 7$
Operation:	$0 \rightarrow R[\text{bit}]$
Status affected:	--
Description:	Clear the bit th position in R.
Cycle:	1
Example:	BCR R,B2 before executing instruction: R=0x5A, B2=0x3, after executing instruction: R=0x52.

ANDIA	AND Immediate with ACC
Syntax:	ANDIA i
Operand:	$0 \leq i < 255$ ACC
Operation:	& i \rightarrow ACC
Status affected:	Z
Description:	The content of ACC register is AND'ed with the 8-bit immediate data i. The result is placed in ACC.
Cycle:	1
Example:	ANDIA i before executing instruction: ACC=0x5A, i=0xAF, after executing instruction: ACC=0x0A, Z=0.

BSR	Set Bit in R
Syntax:	BSR R, bit
Operand:	$0 \leq R \leq 63$ $0 \leq \text{bit} \leq 7$
Operation:	$1 \rightarrow R[\text{bit}]$
Status affected:	--
Description:	Set the bit th position in R.
Cycle:	1
Example:	BSR R,B2 before executing instruction: R=0x5A, B2=0x2, after executing instruction: R=0x5E.

BTRSC	Test Bit in R and Skip if Clear
Syntax:	BTRSC R, bit
Operand:	$0 \leq R \leq 63$ $0 \leq \text{bit} \leq 7$
Operation:	Skip next instruction, if R[bit] = 0.
Status affected:	--
Description:	If R[bit] = 0,, the next instruction which is already fetched is discarded and a NOP is executed instead. Therefore it makes this instruction a two-cycle instruction.
Cycle:	1 or 2(skip)
Example:	BTRSC R, B2 Instruction1 Instruction2 before executing instruction: R=0x5A, B2=0x2, after executing instruction: because R[B2]=0, instruction1 will not be executed, the program will start execute instruction from instruction2.

CALL	Call Subroutine
Syntax:	CALL i
Operand:	$0 \leq i < 255$
Operation:	PC + 1 Top of Stack {PCHBUF, i} → PC
Status affected:	--
Description:	The return address (PC + 1) is pushed onto top of Stack. The 8-bit immediate address I is loaded into PC[7:0] and PCHBUF[2:0] is loaded into PC[10:8].
Cycle:	2
Example:	CALL SUB before executing instruction: PC=A0. Stack pointer=1 after executing instruction: PC=address of SUB, Stack[1] = A0+1, Stack pointer=2.

BTRSS	Test Bit in R and Skip if Set
Syntax:	BTRSS R, bit
Operand:	$0 \leq R \leq 63$ $0 \leq \text{bit} \leq 7$
Operation:	Skip next instruction, if R[bit] = 1.
Status affected:	--
Description:	If R[bit] = 1,, the next instruction which is already fetched is discarded and a NOP is executed instead. Therefore it makes this instruction a two-cycle instruction.
Cycle:	1 or 2(skip)
Example:	BTRSS R, B2 Instruction2 Instruction3 before executing instruction: R=0x5A, B2=0x3, after executing instruction: because R[B2]=1, instruction2 will not be executed, the program will start execute instruction from instruction3.

CALLA	Call Subroutine
Syntax:	CALLA
Operand:	--
Operation:	PC + 1 Top of Stack {TBHP, ACC} → PC
Status affected:	--
Description:	The return address (PC + 1) is pushed onto top of Stack. The contents of TBHP[2:0] is loaded into PC[10:8] and ACC is loaded into PC[7:0].
Cycle:	2
Example:	CALLA before executing instruction: TBHP=0x02, ACC=0x34. PC=A0. Stack pointer=1. after executing instruction: PC=0x234, Stack[1]=A0+1, Stack pointer=2

CLRA	Clear ACC
Syntax:	CLRA
Operand:	--
Operation:	00h → ACC 1 → Z
Status affected:	Z
Description:	ACC is clear and Z is set to 1.
Cycle:	1
Example:	CLRA before executing instruction: ACC=0x55, Z=0. after executing instruction: ACC=0x00, Z=1.

CLRWDT	Clear Watch-Dog Timer
Syntax:	CLRWDT
Operand:	--
Operation:	00h → WDT, 00h → WDT prescaler 1 → /TO 1 → /PD
Status affected:	/TO, /PD
Description:	Executing CLRWDT will reset WDT, Prescaler0 if it is assigned to WDT. Moreover, status bits /TO and /PD will be set to 1.
Cycle:	1
Example:	CLRWDT before executing instruction: /TO=0 after executing instruction: /TO=1

CLRR	Clear R
Syntax:	CLRR R
Operand:	$0 \leq R \leq 63$
Operation:	00h R 1 → Z
Status affected:	Z
Description:	The content of R is clear and Z is set to 1.
Cycle:	1
Example:	CLRR R before executing instruction: R=0x55, Z=0. after executing instruction: R=0x00, Z=1.

COMR	Complement R
Syntax:	COMR R, d
Operand:	$0 \leq R \leq 63$ d = 0, 1.
Operation:	$\sim R \rightarrow \text{dest}$
Status affected:	Z
Description:	The content of R is complemented. If d is 0, the result is stored in ACC. If d is 1, the result is stored back to R.
Cycle:	1
Example:	COMR R, d before executing instruction: R=0xA6, d=1, Z=0. after executing instruction: R=0x59, Z=0.

CMPAR	Compare ACC and R
Syntax:	CMPAR R
Operand:	$0 \leq R \leq 63$
Operation:	R - ACC \rightarrow (No restore)
Status affected:	Z, C
Description:	Compare ACC and R by subtracting ACC from R with 2's complement representation. The content of ACC and R is not changed.
Cycle:	1
Example:	CMPAR R before executing instruction: R=0x34, ACC=12, Z=0, C=0. after executing instruction: R=0x34, ACC=12, Z=0, C=1.

DECR	Decrease R
Syntax:	DECRR, d
Operand:	$0 \leq R \leq 63$ d = 0, 1.
Operation:	R - 1 \rightarrow dest
Status affected:	Z
Description:	Decrease R. If d is 0, the result is stored in ACC. If d is 1, the result is stored back to R.
Cycle:	1
Example:	DECR R, d before executing instruction: R=0x01, d=1, Z=0. after executing instruction: R=0x00, Z=1.

DAA	Convert ACC Data Format from Hexadecimal to Decimal
Syntax:	DAA
Operand:	--
Operation:	ACC(hex) \rightarrow ACC(dec)
Status affected:	C
Description:	Convert ACC data format from hexadecimal format to decimal format after addition operation and restore result to ACC. DAA instruction must be placed after addition operation if decimal format is required.
Cycle:	1
Example:	ADDAR R,d DAA before executing instruction: ACC=0x28, R=0x25, d=0. after executing instruction: ACC=0x53, C=0.

DECRSZ	Decrease R, Skip if 0
Syntax:	DECRSZR, d
Operand:	$0 \leq R \leq 63$ d = 0, 1.
Operation:	R - 1 \rightarrow dest, Skip if result = 0
Status affected:	--
Description:	Decrease R first. If d is 0, the result is stored in ACC. If d is 1, the result is stored back to R. If result is 0, the next instruction which is already fetched is discarded and a NOP is executed instead. Therefore it makes this instruction a two-cycle instruction.
Cycle:	1 or 2(skip)
Example:	DECRSZ R, d instruction2 instruction3 before executing instruction: R=0x1, d=1, Z=0. after executing instruction: R=0x0, Z=1, and instruction will skip instruction2 execution because the operation result is zero.

DISI	Disable Interrupt Globally
Syntax:	DISI
Operand:	--
Operation:	Disable Interrupt, 0 → GIE
Status affected:	--
Description:	GIE is clear to 0 in order to disable all interrupt requests.
Cycle:	1
Example:	DISI before executing instruction: GIE=1, after executing instruction: GIE=0.

GOTO	Unconditional Branch
Syntax:	GOTO i
Operand:	$0 \leq i < 511$
Operation:	{PCHBUF, i} → PC
Status affected:	--
Description:	GOTO is an unconditional branch instruction. The 9-bit immediate address I is loaded into PC[8:0] and PCHBUF[2:1] is loaded into PC[10:9].
Cycle:	2
Example:	GOTO Level before executing instruction: PC=A0. after executing instruction: PC=address of LAB1.

ENI	Enable Interrupt Globally
Syntax:	ENI
Operand:	--
Operation:	Enable Interrupt, 1 → GIE
Status affected:	--
Description:	GIE is set to 1 in order to enable all interrupt requests.
Cycle:	1
Example:	ENI before executing instruction: GIE=0, after executing instruction: GIE=1.

GOTOA	Unconditional Branch
Syntax:	GOTOA
Operand:	--
Operation:	{TBHP, ACC} → PC
Status affected:	--
Description:	GOTOA is an unconditional branch instruction. The content of TBHP[2:0] is loaded into PC[10:8] and ACC is loaded into PC[7:0].
Cycle:	2
Example:	GOTOA before executing instruction: PC=A0. TBHP=0x02, ACC=0x34. after executing instruction: PC=0x234

INCR	Increase R	INT	Interrupt
Syntax:	INCR R, d	Syntax:	INT
Operand:	$0 \leq R \leq 63$ d = 0, 1.	Operand:	--
Operation:	R + 1 → dest.	Operation:	PC + 1 → Top of Stack, 001h → PC
Status affected:	Z	Status affected:	--
Description:	Increase R. If d is 0, the result is stored in ACC. If d is 1, the result is stored back to R.	Description:	Software interrupt. First, return address (PC + 1) is pushed onto the Stack. The address 0x001 is loaded into PC[10:0].
Cycle:	1	Cycle:	3
Example:	INCR R, d before executing instruction: R=0xFF, d=1, Z=0. after executing instruction: R=0x00, Z=1.	Example:	INT before executing instruction: PC=address of INT code after executing instruction: PC=0x01
INCRSZ	Increase R, Skip if 0	IORAR	OR ACC with R
Syntax:	INCRSZ R, d	Syntax:	IORAR R, d
Operand:	$0 \leq R \leq 63$ d = 0, 1.	Operand:	$0 \leq R \leq 63$ d = 0, 1.
Operation:	R + 1 → dest, Skip if result = 0	Operation:	ACC R → dest
Status affected:	--	Status affected:	Z
Description:	Increase R first. If d is 0, the result is stored in ACC. If d is 1, the result is stored back to R. If result is 0, the next instruction which is already fetched is discarded and a NOP is executed instead. Therefore it makes this instruction a two-cycle instruction.	Description:	OR ACC with R. If d is 0, the result is stored in ACC. If d is 1, the result is stored back to R.
Cycle:	1 or 2(skip)	Cycle:	1
Example:	INCRSZ R, d instruction2, instruction3. before executing instruction: R=0xFF, d=1, Z=0. after executing instruction: R=0x00, Z=1. And the program will skip instruction2 execution because the operation result is zero.	Example:	IORAR R, d before executing instruction: R=0x50, ACC=0xAA, d=1, Z=0. after executing instruction: R=0xFA, ACC=0xAA, Z=0.

IORIA	OR Immediate with ACC
Syntax:	IORIA i
Operand:	$0 \leq i < 255$
Operation:	ACC i → ACC
Status affected:	Z
Description:	OR ACC with 8-bit immediate data i. The result is stored in ACC.
Cycle:	1
Example:	IORIA i before executing instruction: i=0x50, ACC=0xAA, Z=0. after executing instruction: ACC=0xFA, Z=0.

IOSTR	Move F-page SFR to ACC
Syntax:	IOSTR F
Operand:	$5 \leq F \leq 15$
Operation:	F-page SFR → ACC
Status affected:	--
Description:	Move F-page SFR F to ACC.
Cycle:	1
Example:	IOSTR F before executing instruction: F=0x55, ACC=0xAA. after executing instruction: F=0x55, ACC=0x55.

IOST	Load F-page SFR to ACC
Syntax:	IOST F
Operand:	$0 \leq F \leq 15$
Operation:	ACC → F-page SFR
Status affected:	--
Description:	F-page SFR F is loaded by content of ACC.
Cycle:	1
Example:	IOST F before executing instruction: F=0x55, ACC=0xAA. after executing instruction: F=0xAA, ACC=0xAA.

LCALL	Call Subroutine
Syntax:	LCALL i
Operand:	$0 \leq i \leq 2047$
Operation:	PC + 1 → Top of Stack, i → PC[10:0]
Status affected:	--
Description:	The return address (PC + 1) is pushed onto top of Stack. The 11-bit immediate address I is loaded into PC[10:0].
Cycle:	2
Example:	LCALL SUB before executing instruction: PC=A0. Stack level=1 after executing instruction: PC=address of SUB, Stack[1]= A0+1, Stack pointer =2.

LGOTO	Unconditional Branch
Syntax:	LGOTO i
Operand:	$0 \leq i \leq 2047$
Operation:	$i \rightarrow PC[10:0]$.
Status affected:	--
Description:	LGOTO is an unconditional branch instruction. The 11-bit immediate address I is loaded into PC[10:0].
Cycle:	2
Example:	LGOTO Level before executing instruction: PC=A0. after executing instruction: PC=address of Level.

MOVIA	Move Immediate to ACC
Syntax:	MOVIA i
Operand:	$0 \leq i < 255$
Operation:	$i \rightarrow ACC$
Status affected:	--
Description:	The content of ACC is loaded with 8-bit immediate data i.
Cycle:	1
Example:	MOVIA i before executing instruction: i=0x55, ACC=0xAA. after executing instruction: ACC=0x55.

MOVAR	Move ACC to R
Syntax:	MOVAR R
Operand:	$0 \leq R \leq 63$
Operation:	$ACC \rightarrow R$
Status affected:	--
Description:	Move content of ACC to R.
Cycle:	1
Example:	MOVAR R before executing instruction: R=0x55, ACC=0xAA. after executing instruction: R=0xAA, ACC=0xAA.

MOVR	Move to R
Syntax:	MOVR R, d
Operand:	$0 \leq R \leq 63$ $d = 0, 1$.
Operation:	$R \rightarrow dest$
Status affected:	Z
Description:	The content of R is move to destination. If d is 0, destination is ACC. If d is 1, destination is R and it can be used to check whether R is zero according to status flag Z after execution.
Cycle:	1
Example:	MOVR R, d before executing instruction: R=0x0, ACC=0xAA, Z=0, d=0. after executing instruction: R=0x0, ACC=0x00, Z=1.

NOP	No Operation
Syntax:	NOP
Operand:	--
Operation:	No operation.
Status affected:	--
Description:	No operation.
Cycle:	1
Example:	NOP before executing instruction: PC=A0 after executing instruction: PC=A0+1

RETIA	Return with Data in ACC
Syntax:	RETIA i
Operand:	$0 \leq i < 255$
Operation:	i → ACC, Top of Stack → PC
Status affected:	--
Description:	ACC is loaded with 8-bit immediate data i and PC is loaded from top of Stack as return address and GIE is set to 1.
Cycle:	2
Example:	RETIA i before executing instruction: GIE=0, Stack pointer =2. i=0x55, ACC=0xAA. after executing instruction: GIE=1, PC=Stack[2], Stack pointer =1. ACC=0x55.

RETIE	Return from Interrupt and Enable Interrupt Globally
Syntax:	RETIE
Operand:	--
Operation:	Top of Stack → PC 1 GIE
Status affected:	--
Description:	The PC is loaded from top of Stack as return address and GIE is set to 1.
Cycle:	2
Example:	RETIE before executing instruction: GIE=0, Stack level=2. after executing instruction: GIE=1, PC=Stack[2], Stack pointer=1.

RET	Return from Subroutine
Syntax:	RET
Operand:	--
Operation:	Top of Stack → PC
Status affected:	--
Description:	PC is loaded from top of Stack as return address.
Cycle:	2
Example:	RET before executing instruction: Stack level=2. after executing instruction: PC=Stack[2], Stack level=1.

RLR Rotate Left R Through Carry

Syntax: RLR R, d
 Operand: $0 \leq R \leq 63$
 $d = 0, 1.$
 Operation: $R[7] \rightarrow C, R[6:0] \rightarrow \text{dest}[7:1],$
 $C \rightarrow \text{dest}[0]$

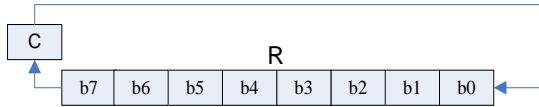

Status affected: C
 Description: The content of R is rotated one bit to the left through flag Carry. If d is 0, the result is placed in ACC. If d is 1, the result is stored back to R.
 Cycle: 1
 Example: RLR R, d
 before executing instruction:
 $R=0xA5, d=1, C=0.$
 after executing instruction:
 $R=0x4A, C=1.$

RRR Rotate Right R Through Carry

Syntax: RRR R, d
 Operand: $0 \leq R \leq 63$
 $d = 0, 1.$
 Operation: $C \rightarrow \text{dest}[7], R[7:1] \rightarrow \text{dest}[6:0],$
 $R[0] \rightarrow C$

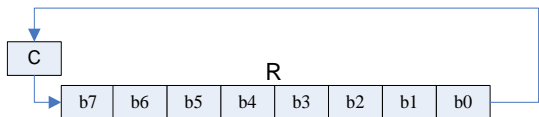

Status affected: C
 Description: The content of R is rotated one bit to the right through flag Carry. If d is 0, the result is placed in ACC. If d is 1, the result is stored back to R.
 Cycle: 1
 Example: RRR R, d
 before executing instruction:
 $R=0xA5, d=1, C=0.$
 after executing instruction:
 $R=0x52, C=1.$

SBCAR Subtract ACC and Carry from R

Syntax: SBCAR R, d
 Operand: $0 \leq R \leq 63$
 $d = 0, 1.$
 Operation: $R + (-ACC) + C \rightarrow \text{dest}$
 Status affected: Z, DC, C
 Description: Subtract ACC and Carry from R with 2's complement representation. If d is 0, the result is placed in ACC. If d is 1, the result is stored back to R.

Cycle: 1
 Example: SBCAR R, d
 (a) before executing instruction:
 $R=0x05, ACC=0x06, d=1,$
 $C=0, .$
 after executing instruction:
 $R=0xFE, C=0. (-2)$
 (b) before executing instruction:
 $R=0x05, ACC=0x06, d=1,$
 $C=1,$
 after executing instruction:
 $R=0xFF, C=0. (-1)$
 (c) before executing instruction:
 $R=0x06, ACC=0x05, d=1,$
 $C=0, .$
 after executing instruction:
 $R=0x00, C=1. (-0), Z=1.$
 (d) before executing instruction:
 $R=0x06, ACC=0x05, d=1,$
 $C=1, .$
 after executing instruction:
 $R=0x1, C=1. (+1)$

SBCIA Subtract ACC and Carry from Immediate

Syntax: SBCIA i

Operand: $0 \leq i < 255$

Operation: $i + (\sim\text{ACC}) + C \rightarrow \text{dest}$

Status affected: Z, DC, C

Description: Subtract ACC and Carry from 8-bit immediate data i with 2's complement representation. The result is placed in ACC.

Cycle: 1

Example: SBCIA i

(a) before executing instruction:
 $i=0x05, \text{ACC}=0x06, C=0,$
 after executing instruction:
 $\text{ACC}=0xFE, C=0. (-2)$

(b) before executing instruction:
 $i=0x05, \text{ACC}=0x06, C=1,$
 after executing instruction:
 $\text{ACC}=0xFF, C=0. (-1)$

(c) before executing instruction:
 $i=0x06, \text{ACC}=0x05, C=0, .$
 after executing instruction:
 $\text{ACC}=0x00, C=1. (-0), Z=1.$

(d) before executing instruction:
 $i=0x06, \text{ACC}=0x05, C=1,$
 after executing instruction:
 $\text{ACC}=0x1, C=1. (+1)$

SFUN Load S-page SFR to ACC

Syntax: SFUN S

Operand: $0 \leq S \leq 15$

Operation: $\text{ACC} \rightarrow \text{S-page SFR}$

Status affected: --

Description: S-page SFR S is loaded by content of ACC.

Cycle: 1

Example: SFUN S

 before executing instruction:
 $S=0x55, \text{ACC}=0xAA.$
 after executing instruction:
 $S=0xAA, \text{ACC}=0xAA.$

SFUNR Move S-page SFR to ACC

Syntax: SFUNR S

Operand: $0 \leq S \leq 15$

Operation: $\text{S-page SFR} \rightarrow \text{ACC}$

Status affected: --

Description: Move S-page SFR S to ACC.

Cycle: 1

Example: SFUNR F

 before executing instruction:
 $R=0x55, \text{ACC}=0xAA.$
 after executing instruction:
 $F=0x55, \text{ACC}=0x55.$

SLEEP	Enter Halt Mode
Syntax:	SLEEP
Operand:	--
Operation:	00h → WDT, 00h → WDT prescaler 1 → /TO 0 → /PD
Status affected:	/TO, /PD
Description:	WDT and Prescaler0 are clear to 0. /TO is set to 1 and /PD is clear to 0. IC enter Halt mode.
Cycle:	1
Example:	SLEEP before executing instruction: /PD=1, /TO=0. after executing instruction: /PD=0, /TO=1.

SUBIA	Subtract ACC from Immediate
Syntax:	SUBIA i
Operand:	$0 \leq i < 255$
Operation:	$i - \text{ACC} \rightarrow \text{ACC}$
Status affected:	Z, DC, C
Description:	Subtract ACC from 8-bit immediate data i with 2's complement representation. The result is placed in ACC.
Cycle:	1
Example:	SUBIA i (a) before executing instruction: i=0x05, ACC=0x06. after executing instruction: ACC=0xFF, C=0. (-1) (b) before executing instruction: i=0x06, ACC=0x05, d=1, . after executing instruction: ACC=0x01, C=1. (+1)

SUBAR	Subtract ACC from R
Syntax:	SUBAR R, d
Operand:	$0 \leq R \leq 63$ d = 0, 1.
Operation:	$R - \text{ACC} \rightarrow \text{dest}$
Status affected:	Z, DC, C
Description:	Subtract ACC from R with 2's complement representation. If d is 0, the result is placed in ACC. If d is 1, the result is stored back to R.
Cycle:	1
Example:	SBCAR R, d (a) before executing instruction: R=0x05, ACC=0x06, d=1, . after executing instruction: R=0xFF, C=0. (-1) (b) before executing instruction: R=0x06, ACC=0x05, d=1, . after executing instruction: R=0x01, C=1. (+1)

SWAPR	Swap High/Low Nibble in R
Syntax:	SWAPR R, d
Operand:	$0 \leq R \leq 63$ d = 0, 1.
Operation:	$R[3:0] \rightarrow \text{dest}[7:4].$ $R[7:4] \rightarrow \text{dest}[3:0]$
Status affected:	--
Description:	The high nibble and low nibble of R is exchanged. If d is 0, the result is placed in ACC. If d is 1, the result is stored back to R.
Cycle:	1
Example:	SWAPR R, d before executing instruction: R=0xA5, d=1. after executing instruction: R=0x5A.

TABLEA	Read ROM data
Syntax:	TABLEA
Operand:	--
Operation:	ROM data{ TBHP, ACC } [7:0] → ACC ROM data{TBHP, ACC} [13:8] → BHD.
Status affected:	--
Description:	The 8 least significant bits of ROM pointed by {TBHP[2:0], ACC} is placed to ACC. The 6 most significant bits of ROM pointed by {TBHP[2:0], ACC} is placed to TBHD[5:0].
Cycle:	2
Example:	TABLEA before executing instruction: TBHP=0x02, CC=0x34. TBHD=0x01. ROM data[0x234]= 0x35AA after executing instruction: TBHD=0x35, ACC=0xAA.

T0MDR	Move T0MD to ACC
Syntax:	T0MDR
Operand:	--
Operation:	T0MD → ACC
Status affected:	--
Description:	Move the content of T0MD to ACC.
Cycle:	1
Example:	T0MDR before executing instruction T0MD=0x55, ACC=0xAA. after executing instruction ACC=0x55.

T0MD	Load ACC to T0MD
Syntax:	T0MD
Operand:	--
Operation:	ACC → T0MD
Status affected:	--
Description:	The content of T0MD is loaded by ACC.
Cycle:	1
Example:	T0MD before executing instruction: T0MD=0x55, ACC=0xAA. after executing instruction: T0MD=0xAA.

XORAR	Exclusive-OR ACC with R
Syntax:	XORAR R, d
Operand:	$0 \leq R \leq 63$ $d = 0, 1.$
Operation:	$ACC \oplus R \rightarrow dest$
Status affected:	Z
Description:	Exclusive-OR ACC with R. If d is 0, the result is placed in ACC. If d is 1, the result is stored back to R.
Cycle:	1
Example:	XORAR R, d before executing instruction: R=0xA5, ACC=0xF0, d=1. after executing instruction: R=0x55.

XORIA	Exclusive-OR Immediate with ACC
--------------	--

Syntax:	XORIA i
Operand:	0 $\leq i < 255$
Operation:	ACC \oplus ACC
Status affected:	Z
Description:	Exclusive-OR ACC with 8-bit immediate data i. The result is stored in ACC.
Cycle:	1
Example:	XORIA i before executing instruction: i=0xA5, ACC=0xF0. after executing instruction: i=0x55.

5. Configuration Words

Item	Name	Options
1	High Oscillator Frequency	1. I_HRC 2. E_HXT 3. E_XT
2	Low Oscillator Frequency	1. I_LRC 2. E_LXT
3	High IRC Frequency	1. 1MHz 2. 2MHz 3. 4MHz 4. 8MHz 5. 16MHz 6. 20MHz
4	High Crystal Oscillator	1. >6MHz 2. 8MHz 3. 10MHz 4. 12MHz 5. ≥16MHz
5	Instruction Clock	1. 2 oscillator period 2. 4 oscillator period
6	WDT	1. Watchdog Enable (Software control) 2. Watchdog Disable (Always disable)
7	WDT Event	1. Watchdog Reset 2. Watchdog Interrupt
8	Timer0 source	1. EX_CKI 2. I_LRC
9	PB.2	1. PB.2 is I/O 2. PB.2 is PWM 3. PB.3 is Buzzer
10	PB.3	1. PB.3 is I/O 2. PB.3 is reset
11	PB.4	1. PB.4 is I/O 2. PB.4 is instruction clock output
12	IR Current	1. Normal=60mA 2. Large=340mA
13	Startup Time	1. 18ms 2. 72ms 3. 288ms
14	WDT Time Base	1. 3.5ms 2. 15ms 3. 60ms 4. 250ms
15	Noise Filter (High_EFT)	1. Enable 2. Disable
16	LVR Setting	1. Register Control 2. LVR Always On
17	LVR Voltage	1. 1.8V 2. 2.0V 3. 2.2V 4. 2.4V 5. 2.7V 6. 3.0V 7. 3.2V 8. 3.5V 9. 4.2V
18	VDD Voltage	1. 3.0V 2. 4.5V 3. 5.0V

Table 16 Configuration Words

6. Electrical Characteristics

6.1 Absolute Maximum Rating

Symbol	Parameter	Rated Value	Unit
$V_{DD} - V_{SS}$	Supply voltage	-0.5 ~ +6.0	V
V_{IN}	Input voltage	$V_{SS}-0.3V \sim V_{DD}+0.3$	V
T_{OP}	Operating Temperature	-40 ~ +85	°C
T_{ST}	Storage Temperature	-40 ~ +125	°C

6.2 DC Characteristics

(All refer $F_{INST}=F_{HOSC}/4$, $F_{HOSC}=16MHz@I_HRC$, WDT enabled, ambient temperature $T_A=25^\circ C$ unless otherwise specified.)

Symbol	Parameter	VDD	Min.	Typ.	Max.	Unit	Condition
V_{DD}	Operating voltage	--	3.3	--	5.5	V	$F_{INST}=20MHz @ I_HRC/2$
			2.2				$F_{INST}=20MHz@I_HRC/4$
			3.0				$F_{INST}=16MHz@E_HXT/2$
			2.0				$F_{INST}=16MHz@E_HXT/4$
			2.0				$F_{INST}=8MHz@I_LRC/4 \& I_LRC/2$
							$F_{INST}=8MHz@E_LXT/4 \& E_LXT/2$
			1.8				$F_{INST}=4MHz@I_LRC/4 \& I_LRC/2$
							$F_{INST}=4MHz@E_LXT/4 \& E_LXT/2$
			1.8				$F_{INST}=32KHz@I_LRC/4 \& I_LRC/2$
	$F_{INST}=32KHz@E_LXT/4 \& E_LXT/2$						
V_{IH}	Input high voltage	5V	4.0	--	--	V	RSTb, EX_CKI, INT (0.8VDD)
		3V	2.4	--	--		
		5V	2.0	--	--	V	All other I/O pins
		3V	1.5	--	--		
V_{IL}	Input low voltage	5V	--	--	1.0	V	RSTb, EX_CKI, INT (0.2VDD)
		3V	--	--	0.6		
		5V	--	--	0.8	V	All other I/O pins
		3V	--	--	0.45		
I_{OH}	Output high current	5V		-33		mA	$V_{OH}=4.0V$
		3V		-20			$V_{OH}=2.0V$
I_{OL}	Output low current (Large current)	5V		90		mA	$V_{OL}=1.0V$
		3V		60			
I_{LIR}	IR sink current	5V		420		mA	Large IR
		3V		340			
I_{OP}	Operating current	Normal Mode					
		5V		3		mA	$F_{HOSC}=20MHz@I_HRC/2 \& E_HXT/2$
		3V		1.5			
		5V		2		mA	$F_{HOSC}=20MHz@I_HRC/4 \& E_HXT/4$
		3V		1			
		5V		2.5		mA	$F_{HOSC}=16MHz@I_HRC/2 \& E_HXT/2$
3V		1.2					

Symbol	Parameter	VDD	Min.	Typ.	Max.	Unit	Condition		
		5V		1.6		mA	$F_{HOSC}=16\text{MHz}@I_{HRC}/4$ & $E_{HXT}/4$		
		3V		0.9					
		5V		1.5		mA	$F_{HOSC}=8\text{MHz}@I_{HRC}/2$ & $E_{HXT}/2$		
		3V		0.9					
		5V		1.2		mA	$F_{HOSC}=8\text{MHz}@I_{HRC}/4$ & $E_{HXT}/4$		
		3V		0.7					
		5V		1.2		mA	$F_{HOSC}=4\text{MHz}@I_{HRC}/2$ & $E_{HXT}/2$		
		3V		0.7					
		5V		1		mA	$F_{HOSC}=4\text{MHz}@I_{HRC}/4$ & $E_{HXT}/4$		
		3V		0.5					
		5V		0.8		mA	$F_{HOSC}=1\text{MHz}@I_{HRC}/2$ & $E_{HXT}/2$		
		3V		0.4					
		5V		0.8		mA	$F_{HOSC}=1\text{MHz}@I_{HRC}/4$ & $E_{HXT}/4$		
		3V		0.4					
		Slow mode							
				5V		10		uA	F_{HOSC} disabled, $F_{LOSC}=32\text{KHz}@I_{LRC}/2$
3V				6					
5V				12		uA	F_{HOSC} disabled, $F_{LOSC}=32\text{KHz}@E_{LXT}/2$.		
3V				5					
5V				8		uA	F_{HOSC} disabled, $F_{LOSC}=32\text{KHz}@I_{LRC}/4$		
3V				5					
5V				10		uA	F_{HOSC} disabled, $F_{LOSC}=32\text{KHz}@E_{LXT}/4$.		
3V				4					
I_{STB}	Standby current	5V		5		uA	Standby mode, F_{HOSC} disabled, $F_{LOSC}=32\text{KHz}@I_{LRC}/4$		
		3V		2					
I_{HALT}	Halt current	5V			0.5	uA	Halt mode, WDT disabled.		
		3V			0.2				
		5V			5	uA	Halt mode, WDT enabled.		
		3V			2				
R_{PH}	Pull-High resistor	5V		55		K Ω	Pull-High resistor		
		3V		105					
R_{PL}	Pull-Low resistor	5V		55		K Ω	Pull-Low resistor		
		3V		105					

6.3 AC Characteristics

(All refer $F_{INST}=F_{HOSC}/4$, $F_{HOSC}=16\text{MHz}@I_{HRC}$, WDT enabled, ambient temperature $T_A=25^\circ\text{C}$ unless otherwise specified.)

Symbol	Parameter	VDD	Min.	Typ.	Max.	Unit	Condition
F_{E_HXT}	E_HXT crystal mode	5V	6	--	20	MHz	$F_{INST}=F_{E_HXT}/4$.
		3V	6	--	20		
F_{E_XT}	E_XT crystal mode	5V	455	--	8,000	KHz	$F_{INST}=F_{E_XT}/4$. (8MHz Vop min = 2.5v)
		3V	455	--	8,000		

Symbol	Parameter	VDD	Min.	Typ.	Max.	Unit	Condition
F _{E_LXT}	E_LXT crystal mode	5V	--	--	32768	Hz	F _{INST} =F _{E_LXT} /4.
		3V	--	--	32768		
F _{I_HRC}	I_HRC RC mode	5V	16	--	20	MHz	V _{DD} =2.2~5.5V, T _A =25°C
		3V	16	--	20		V _{DD} =5.0V, T _A =0~70°C
F _{I_LRC}	I_LRC RC mode	5V	--	32	--	KHz	V _{DD} =2.2~5.5V, T _A =25°C
		3V	--	32	--		V _{DD} =5.0V, T _A =0~70°C
T _{WDT}	WDT time base	5V	--	18	--	ms	Configuration word is default value.
		3V	--	18	--		

6.4 Characteristic Graph

6.4.1 Frequency vs. VDD of I_HRC

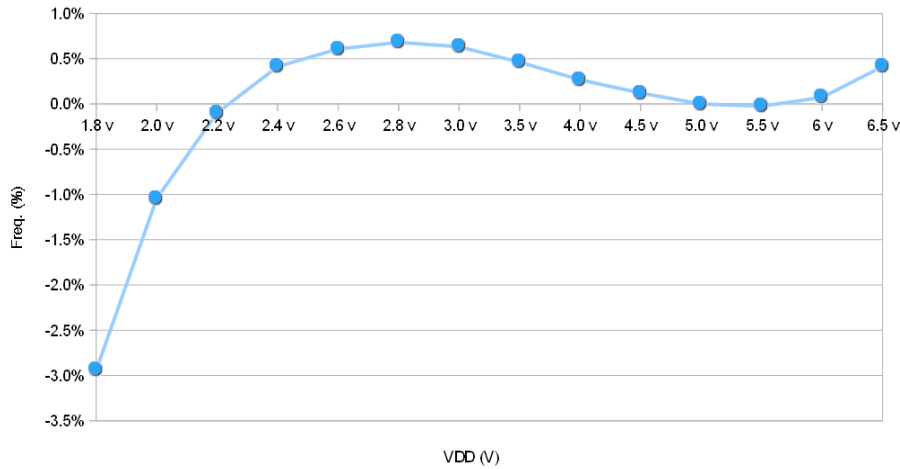

6.4.2 Frequency vs. Temperature of I_HRC

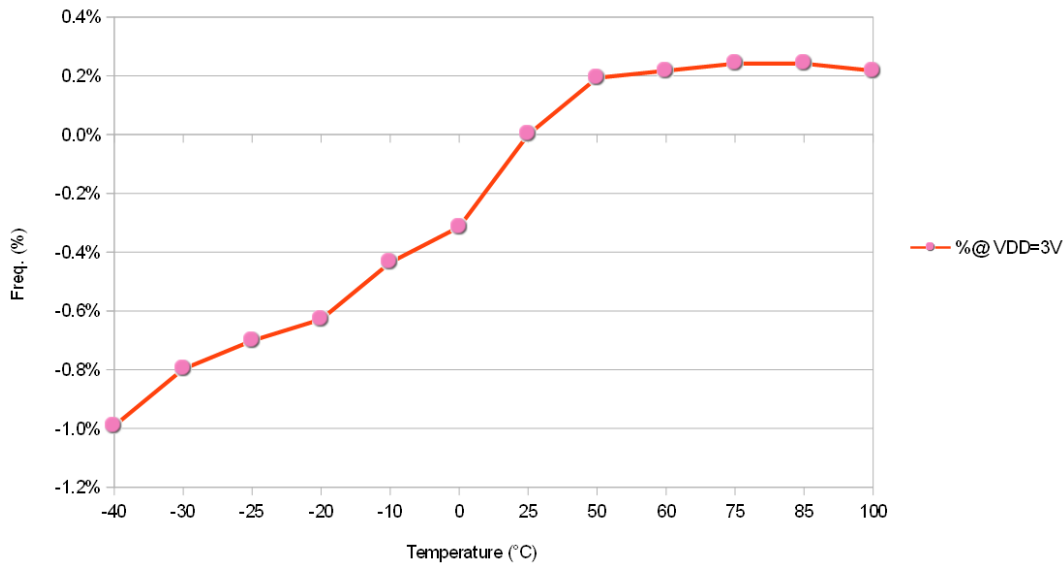

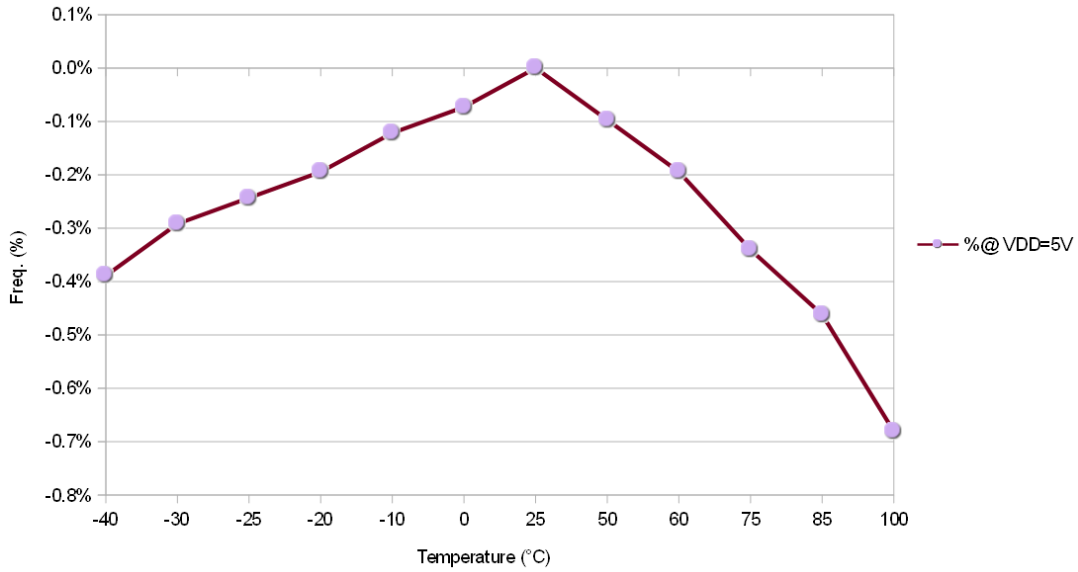

6.4.3 Frequency vs. VDD of I_LRC

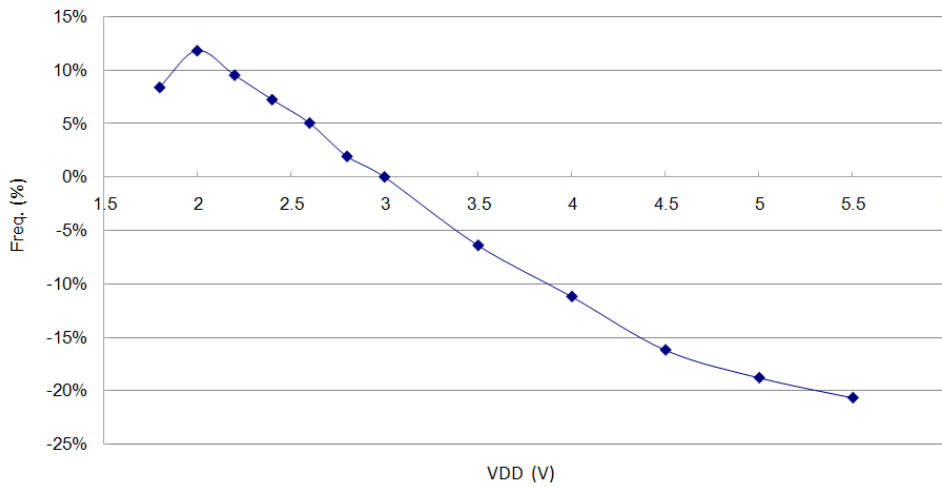

6.4.4 Frequency vs. Temperature of I_LRC

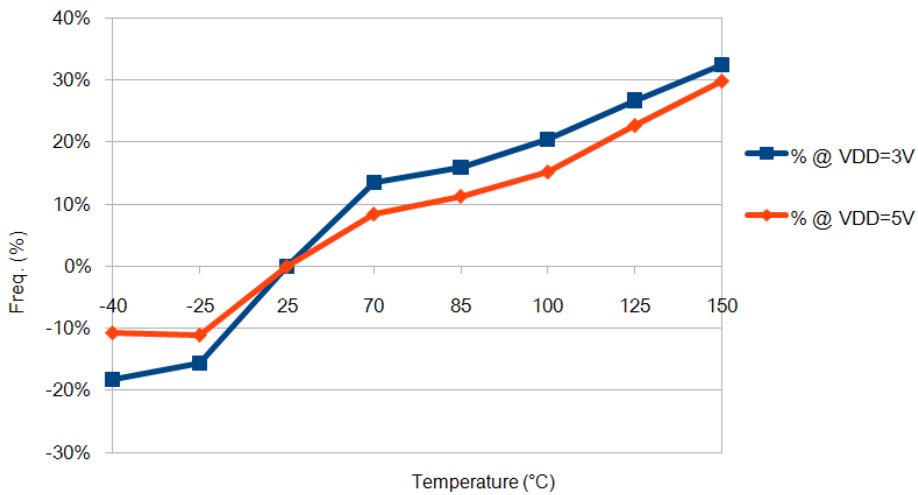

6.5 Recommended Operating Voltage

Recommended Operating Voltage (Temperature range : -40 °C ~ +85 °C)

Frequency	Min. Voltage	Max. Voltage	LVR : default (25 °C)	LVR : Recommended (-40 °C ~ +85 °C)
20M/2T	3.3V	5.5V	3.6V	4.2V
16M/2T	3.0V	5.5V	3.0V	3.6V
20M/4T	2.2V	5.5V	2.4V	3.0V
16M/4T	2.0V	5.5V	2.2V	2.4V
8M/2T/(2T or 4T)	2.0V	5.5V	2.2V	2.4V
<= 6M/(2T or 4T)	1.8V	5.5V	1.8V	2.0V

6.6 LVR vs. Temperature

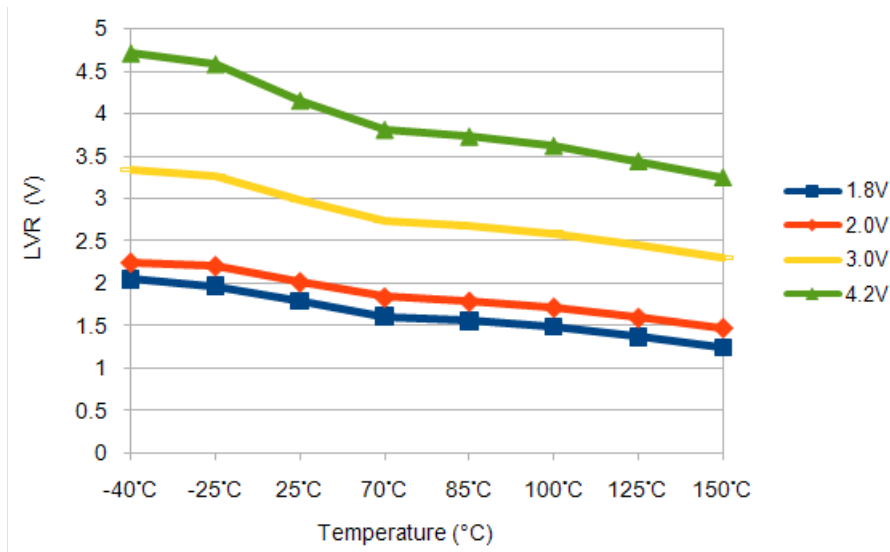

7. DIE PAD Diagram

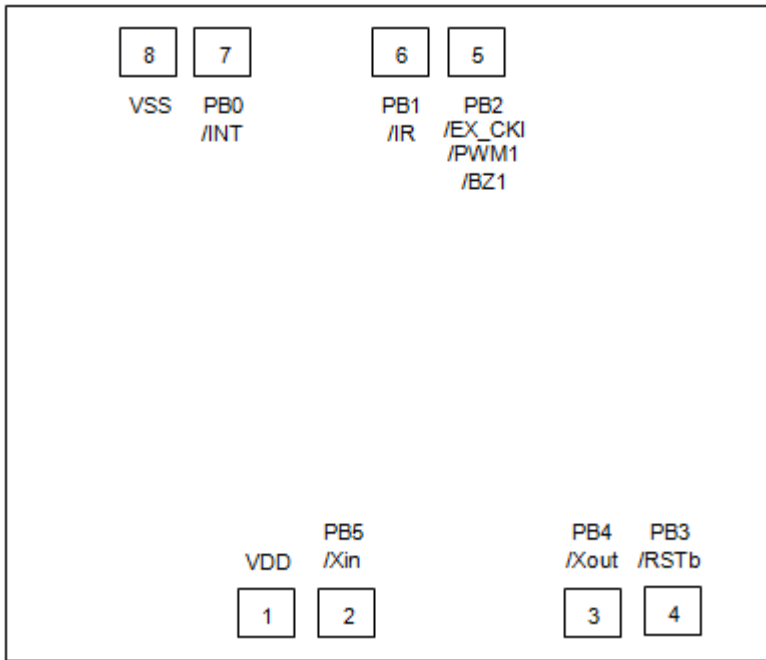

8. Package Dimension

8.1 6-Pin Plastic SOT23-6 (63 mil)

	INCHES			MILLIMETERS		
	MIN	TYP	MAX	MIN	TYP	MAX
A	-	-	0.057	-	-	1.45
A1	-	-	0.006	-	-	0.15
A2	0.035	0.045	0.051	0.90	1.15	1.30
b	0.012	-	0.020	0.30	-	0.50
c	0.003	-	0.009	0.08	-	0.22
D	0.114 BSC			2.90 BSC		
E	0.110 BSC			2.80 BSC		
E1	0.063 BSC			1.60 BSC		
e	0.037 BSC			0.95 BSC		
e1	0.075 BSC			1.90 BSC		
L	0.012	0.018	0.024	0.30	0.45	0.60
L1	0.024 REF			0.60 REF		
L2	0.010 BSC			0.25 BSC		
°M	5°	10°	15°	5°	10°	15°

Note: For SOT23-6 IC, 3000 units per reel.

8.2 8-Pin Plastic SOP (150 mil)

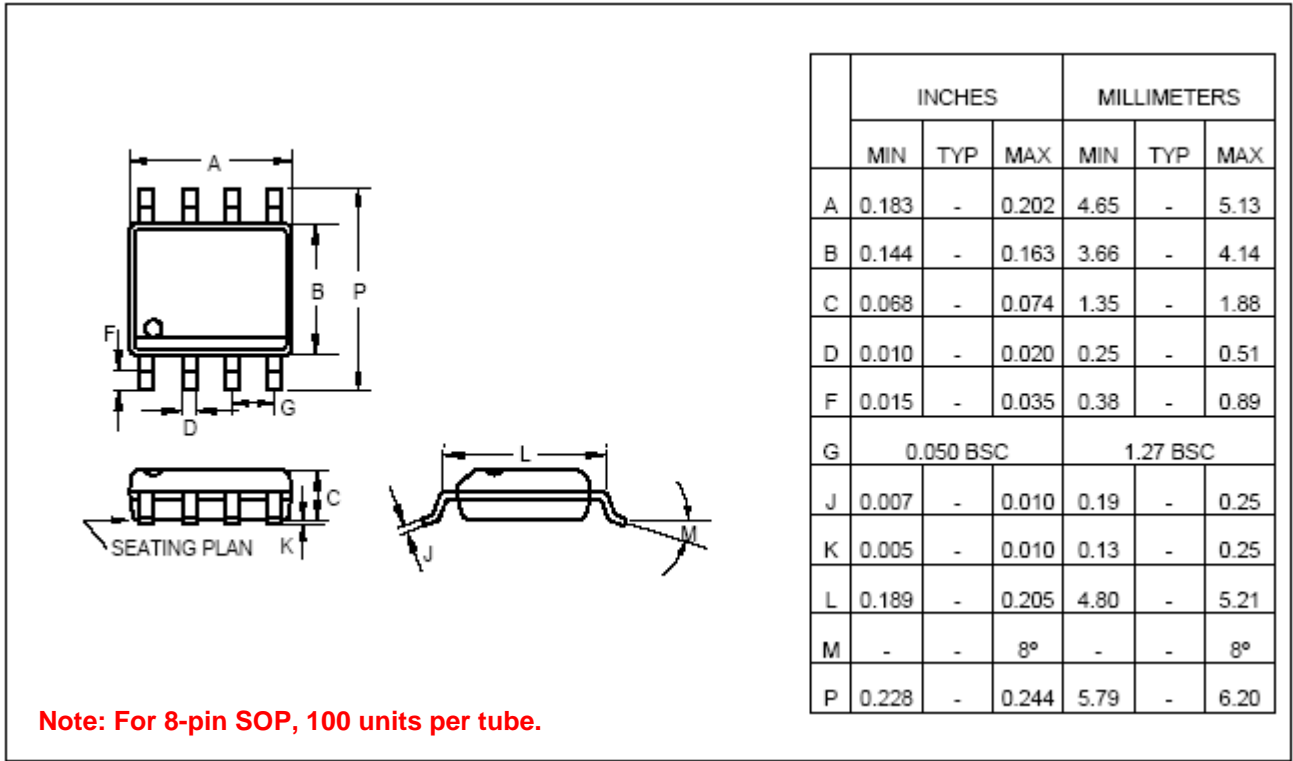

8.3 8-Pin Plastic DIP (300 mil)

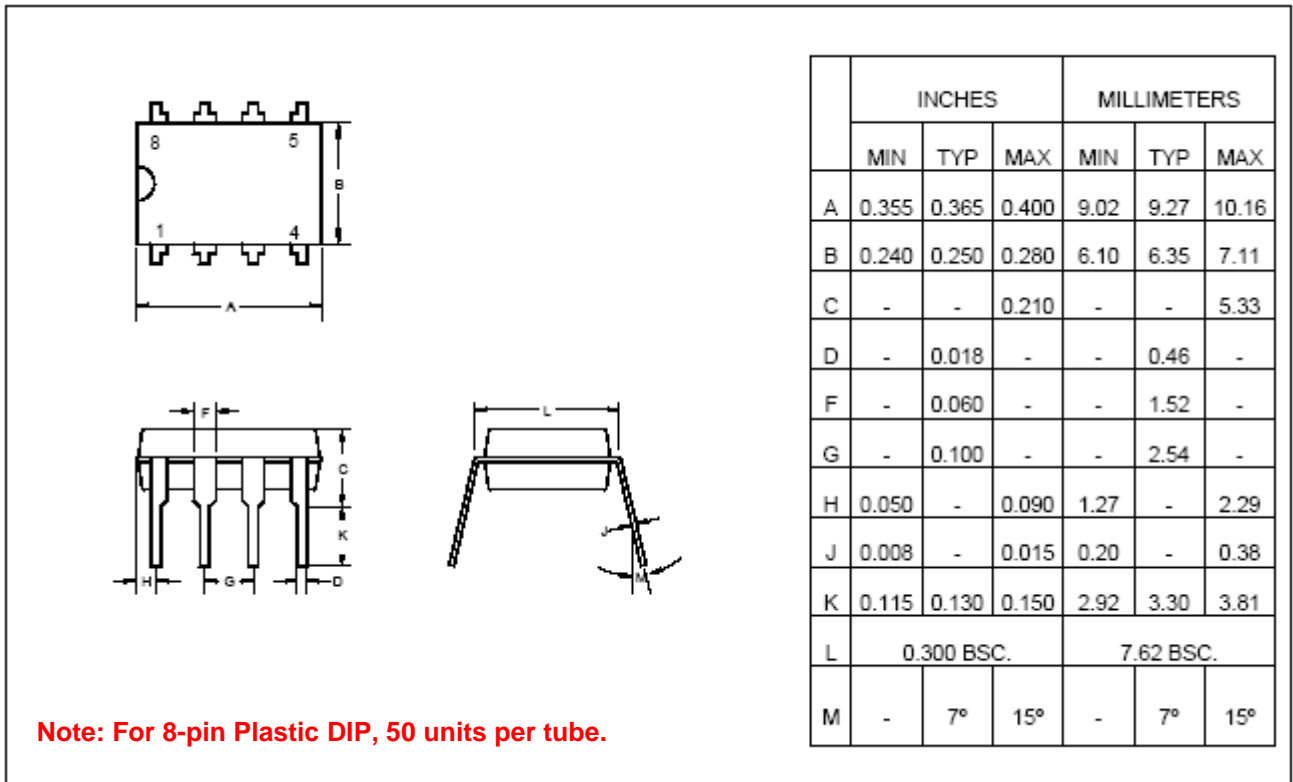

9. Ordering Information

P/N	Package Type	Pin Count	Package Size
NY8A051A	Die	--	--
NY8A051AS6	SOT23-6	6	63 mil
NY8A051AS8	SOP	8	150 mil
NY8A051AP8	PDIP	8	300 mil