



九齊科技股份有限公司
Nyquest Technology Co., Ltd.

DATA SHEET

NY9M005A

Single Channel 0.6A Motor Driver

Version 1.1

Apr. 16, 2014

NYQUEST TECHNOLOGY CO. reserves the right to change this document without prior notice. Information provided by NYQUEST is believed to be accurate and reliable. However, NYQUEST makes no warranty for any errors which may appear in this document. Contact NYQUEST to obtain the latest version of device specifications before placing your orders. No responsibility is assumed by NYQUEST for any infringement of patent or other rights of third parties which may result from its use. In addition, NYQUEST products are not authorized for use as critical components in life support devices/systems or aviation devices/systems, where a malfunction or failure of the product may reasonably be expected to result in significant injury to the user, without the express written approval of NYQUEST.

Revision History

<i>Version</i>	<i>Date</i>	<i>Description</i>	<i>Modified Page</i>
1.0	2014/02/27	New release.	-
1.1	2014/04/16	<ol style="list-style-type: none">1. Modify the output current capability from 500mA to 600mA.2. Modify thermal resistance and power dissipation of SOP-8.3. Modify the value of R_{ON} and I_{OUT}.	3, 4 6 6

1. 概述

NY9M005A 為單晶片CMOS的雙向馬達驅動IC，利用大型積體電路(LSI)製造技術，具有低電源及低成本的特性，可應用於低電壓工作模式。電路採用H橋架構，內置功率 MOSFET 開關，可實現對直流電機做 正轉、反轉、煞車、停止 四個功能的控制。

2. 功能

- (1). 寬廣的工作電壓： 1.8V ~ 5.5V。
- (2). 內置 PMOS/NMOS 功率開關的 H 橋驅動器。
- (3). 支援4種操作模式：正轉 / 反轉 / 剎車 / 停止。
- (4). 低待機電流 (Typ.=0.1uA)。
- (5). 600mA 以上電流輸出能力。
- (6). 內建過溫保護功能。(TSD, Thermal Shutdown)
- (7). CMOS 輸入，輸入腳無需外加限流電阻，且輸入腳內建下拉電阻。
- (8). 高達 5KV 的人體靜電模式 (HBM) 的 ESD 保護。
- (9). 提供 SOT23-6 和 SOP-8 封裝。

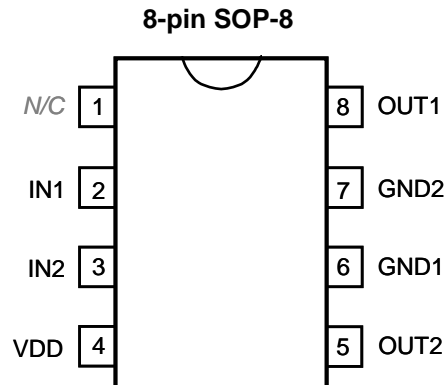
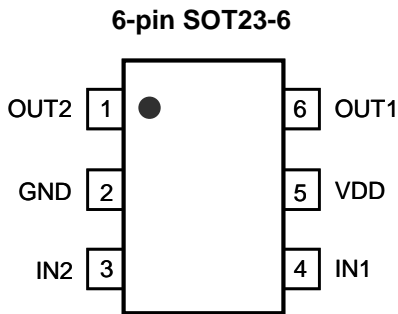

1. GENERAL DESCRIPTION

NY9M005A is a single-chip bi-directional motor driver CMOS IC for low-voltage applications. It is designed with LSI high technology with a low-power and low-cost process. It has H bridge driver of built-in MOSFET power switch to provide Forward / Reverse / Brake / Stop function for motor driver applications.

2. FEATURES

- (1). Wide operating voltage: 1.8V ~ 5.5V.
- (2). H bridge driver of internal PMOS/NMOS power switches.
- (3). Support 4 operating mode: Forward / Backward / Brake / Stop.
- (4). Low standby current. (Typ.=0.1uA)
- (5). Over 600mA output current capability.
- (6). Built-in Thermal Shutdown (TSD) circuit.
- (7). CMOS input. No current-limit resistance required and built-in input pull-low resistance.
- (8). High 5KV Human Body Mode (HBM) ESD protection.
- (9). SOT23-6 and SOP-8 package type are available.

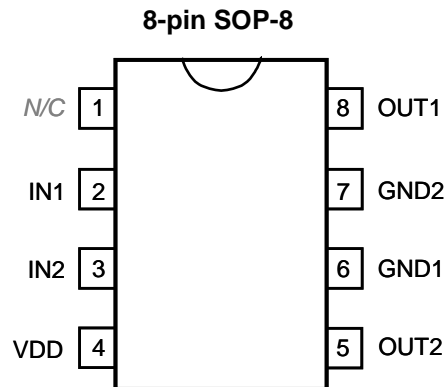
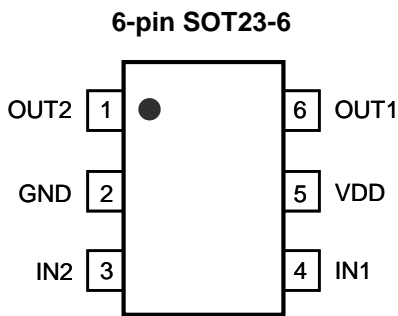

3. BLOCK DIAGRAM

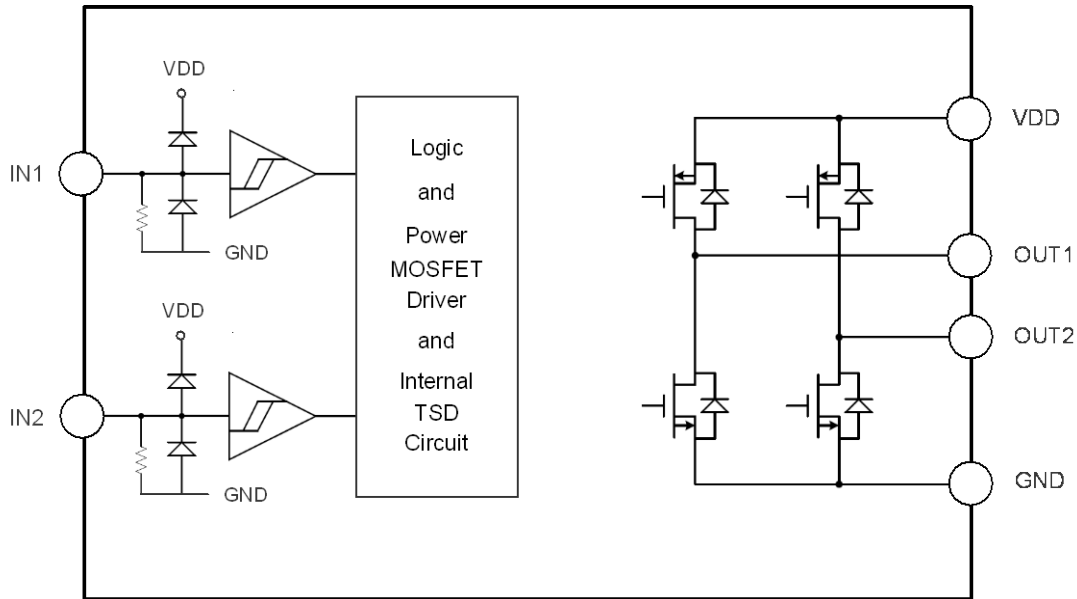

4. PIN DESCRIPTION

Pin Name	Pin No. (SOT23-6 / SOP8)	ATTR.	Description
IN1	4 / 2	I	Forward rotation logic input.
IN2	3 / 3	I	Backward rotation logic input.
OUT1	6 / 8	O	Forward rotation output.
OUT2	1 / 5	O	Backward rotation output.
VDD	5 / 4	Power	Positive power.
GND	2 / 6, 7	Power	Negative power.
N/C*	- / 1	-	No connection.

* N/C pin is suggested connecting to VDD for pin-to-pin compatible with NY9M008AS8 at PCB layout.

5. FUNCTION DESCRIPTION

IN1	IN2	OUT1	OUT2	Function
0	0	Z (Off)	Z (Off)	Stop (Standby)
1	0	1	0	Forward
0	1	0	1	Backward
1	1	0	0	Brake

6. ELECTRICAL CHARACTERISTICS

6.1 Absolute Maximum Rating

Symbol	Parameter	Rating	Unit	
$V_{DD} - V_{SS}$	Supply voltage	-0.5 ~ +6.0	V	
$I_{OUT-PEAK}$	Output peak current	1.0	A	
θ_{JA}	Thermal resistance (Junction to Ambient)	SOT23-6	180	°C/W
		SOP-8	150	
P_D	Power dissipation	SOT23-6	0.7	W
		SOP-8	0.8	
T_A	Operating ambient temperature	-40 ~ +85	°C	
T_J	Operating junction temperature	+150	°C	
T_{ST}	Storage temperature	-55 ~ +150	°C	

6.2 DC Characteristics *($V_{DD}=4.5V$, $T_A=25^\circ C$, unless otherwise specified)*

Symbol	Parameter	Min.	Typ.	Max.	Unit	Condition
V_{DD}	Operating voltage	1.8		5.5	V	
I_{SB}	Standby current		0.1	1	μA	IN1=IN2=0
I_{OP}	Operating current	$V_{DD} = 3.0V$	35		μA	IN1=1, IN2=0 or IN1=0, IN2=1 or IN1=1, IN2=1
		$V_{DD} = 4.5V$	50		μA	
I_{IH}	Input high current (12k Ω pull-low resistance)		250		μA	$V_{IH} = 3.0V$
			370		μA	$V_{IH} = 4.5V$
V_{IH}	Input high voltage	$0.7V_{DD}$			V	
V_{IL}	Input low voltage			$0.3V_{DD}$	V	
R_{ON}	Output resistance (SOT23-6 Package)		1.3		Ω	$I_{OUT} = 200mA$
			1.6		Ω	$I_{OUT} = 500mA$
			2.0		Ω	$I_{OUT} = 800mA$
	Output resistance (SOP-8 Package)		1.4		Ω	$I_{OUT} = 200mA$
			1.8		Ω	$I_{OUT} = 500mA$
			2.3		Ω	$I_{OUT} = 800mA$
I_{OUT}	Output continuous current <i>(* with PCB heat dissipation)</i>		650	800*	mA	SOT23-6
			600	750*	mA	SOP-8
I_{PULSE}	Pulsed drain current			2.0	A	Pulse width < 20ms
T_{RISE}	Output rise time		300		ns	PWM=20kHz, Duty=50%
T_{FALL}	Output fall time		120		ns	
T_{RP}	Input-to-Output response time		150		ns	
T_{TSD}	Thermal shutdown (TSD)		150		°C	Junction temperature
T_{TSDH}	Thermal shutdown hysteresis		35		°C	

7. APPLICATION CIRCUIT

(1) One Motor Bi-Directional Control

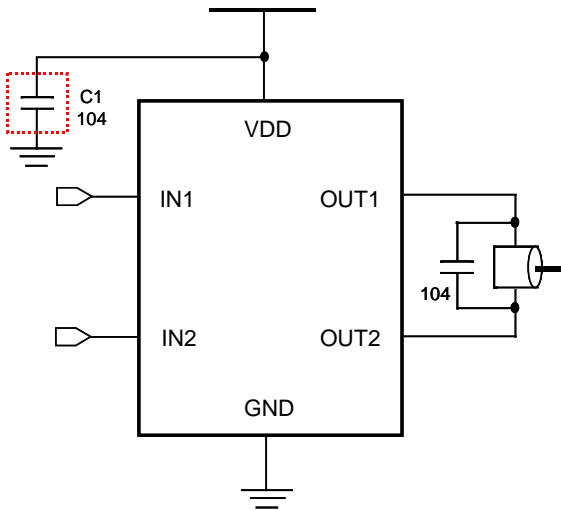

(2) Two Motors Directional Control

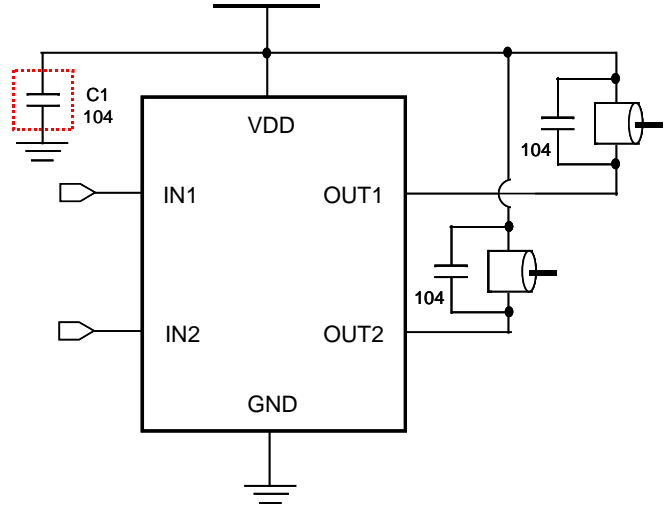

** In normal application, C1 (0.1uF) can be saved, but please reserve C1 space at PCB layout.*

8. DIE PAD DIAGRAM

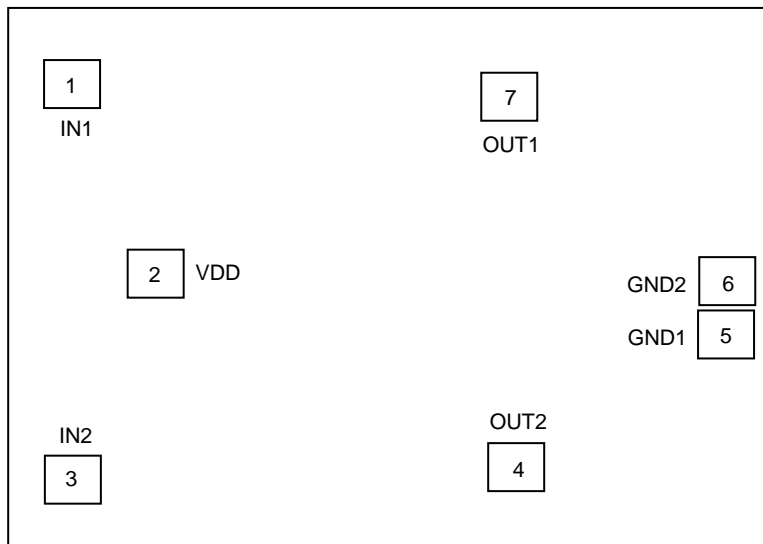

* The IC substrate must be connected to GND or Floating.

9. PACKAGE DIMENSION

9.1 6-Pin Plastic SOT23-6 (63 mil)

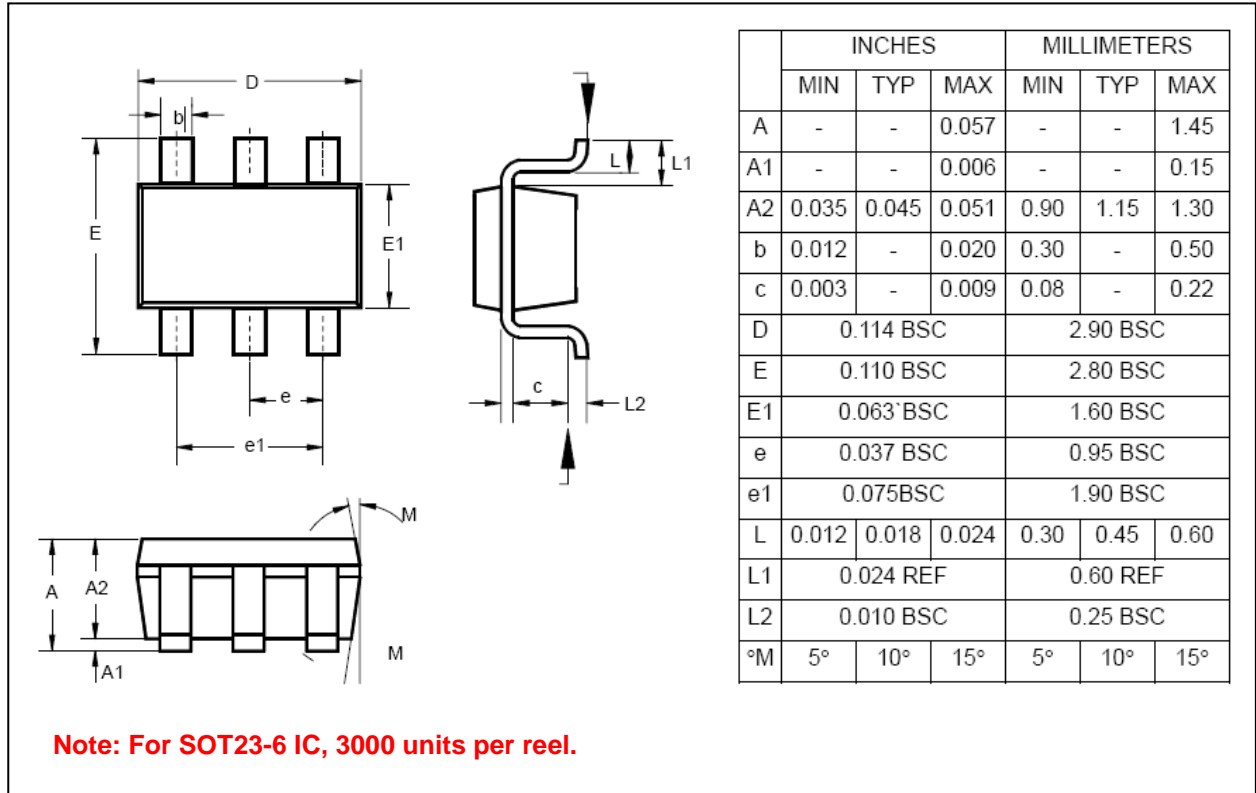

9.2 8-Pin Plastic SOP (150 mil)

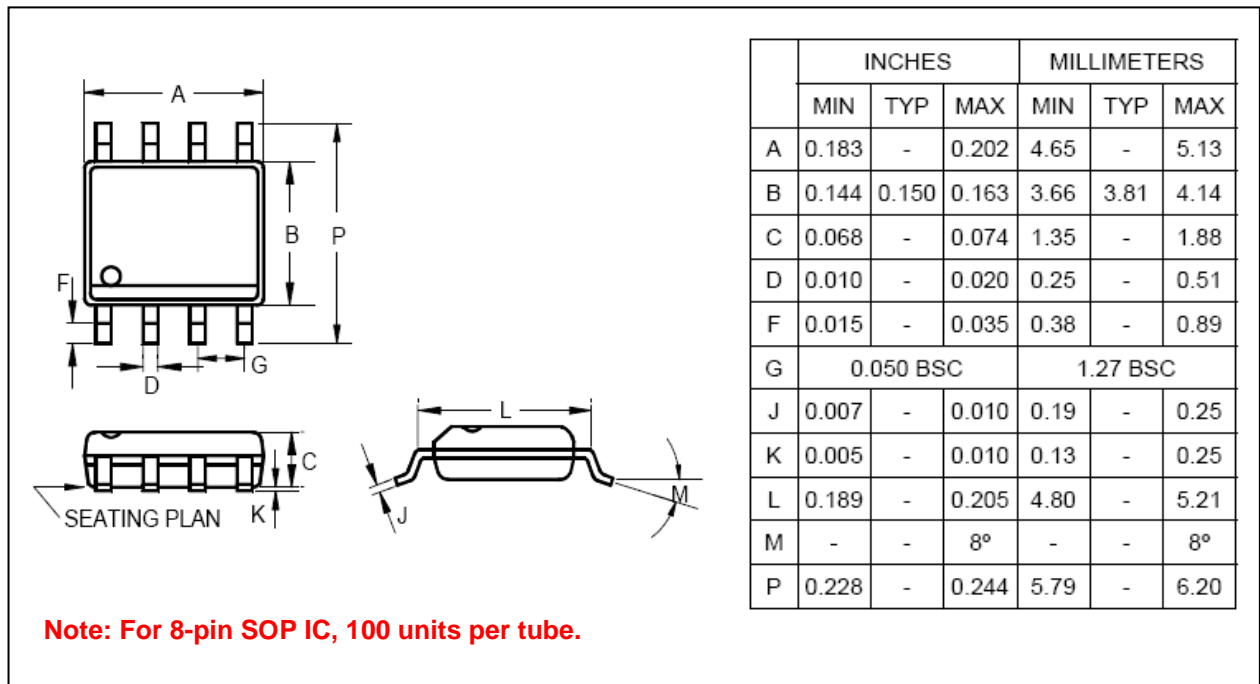

10. ORDERING INFORMATION

<i>P/N</i>	<i>Shipping Type</i>	<i>Remarks</i>
NY9M005A	Die	-
NY9M005AS6	SOT23-6	Width 63 mil.
NY9M005AS8	SOP-8	Width 150 mil.